



SAISON 7



MOUSTACHE
BIKES

www.moustachebikes.com

powered by
 **BOSCH**



THE NOSE ON THE (MOUSTACHE) HANDLEBAR...

... every day since 2011, both literally and figuratively!

Every day the company evolves. We started with 2 people, today we are over 50 and we keep recruiting every month!

How many efforts to provide for all our team members, how many challenges, how many barriers to jump every day? But what satisfaction and pride to carry such a project! The nose on the handlebar, there is no better expression to symbolize the Moustache adventure!

The nose on the Moustache handlebars is once again every day to commute to work or for leisure. In the literal sense this time, but with a different meaning.

What a pleasure to disconnect a few moments from the fast-moving world we live in, to commune with nature, to feel free, incredibly free! There is no better way to recharge your batteries in just a few kilometres.

What a pleasure to taste the magical sensations of the electric bike, the emotions and benefits it provides!

What a pleasure to cross day by day more and more cyclists in our streets of Epinal or elsewhere. Things change, softly, but they change! New bicycle routes are emerging. New users point the tip of their handlebar, you maybe.

We sometimes oppose different forms of cycling, traditional, electric, sports, leisure, road, city, mountain biking... for us, there is only one passion, a deep

love for bicycle that only asks to develop, over and over again. We only see bridges between usages. Our Samedi 27 Xroad, our most versatile model, is the best example. What a great satisfaction to see you riding it every day of the week leaving your car in the garage and to cross your path once again on a weekend cycling with family or friends...

It is this satisfaction that drives and motivates our team on a daily basis to develop a range that is always closer to your needs.

Thank you all for your commitment and your confidence during the last six years, we wish you a nice season 7 the nose on the Moustache handlebar of course :-{D

Credits: Editor: Cycle Me SAS / Text: Emmanuel Antonot / Graphics: Christine Antonot / Photos : Bruce Aufrere, Raoul Gilibert, Sam Needham, Mathieu Rousseau / Actual products may vary / All rights reserved / Printer: Imprimerie de Champagne / Printed in France in August 2017 / Please do not litter. Moustache, a Cycle Me brand / RCS Epinal 533 727 111 / SAS with a capital of €300 K / 9, rue du Colonel Demange / 88190 Golbey / E-mail: contact@moustachebikes.com / Website: www.moustachebikes.com



WHY MOUSTACHE ?

The moustache has been an integral part of the history of the bicycle for a long time now. Look no further than the famous moustache handlebar! Our handlebars are innovative and can be considered as a modern take on the famous moustache handlebars of the past.

Every moustache is unique, every moustache is recognizable, every moustache has a strong identity, just like our bikes!

// Moustache is the strong belief that e-bikes are an incredible opportunity for the development of cycling! As we see it, they are an excellent alternative to cars. A quality e-bike can bring happiness, whether it be in an urban environment, or leisure rides, or for more intense riding.

// It's a certain vision of the e-bike. A different, modern, innovative and

qualitative vision. It's the desire to consider the rider as our priority, the center of our thought and development process. It's the desire to offer bikes that are both unique and rewarding by combining design, comfort and ease of use.

// Moustache is also a walk bike for learning to ride. It's the only bike without electric pedal assistance, but

for us it's one of the most important bikes in our collection: it's a first bike, the one that will ignite a passion in the youngest of riders!

// Moustache is a structured collection with 8 families to cover all the different riding needs: urban, all road, road, mountain bike and kids' bikes, so you can find the right Moustache for you!



THE COMPANY



Moustache is based in the Vosges region of France, home to our childhood memories, our families, and our values. We strongly believe that the strength of a company is based above all on its employees, and we've built ours around our complementary skills. After starting out as two bike-lovers crazy enough to embark on such an adventure - Manu (development) and Greg (sales) - we now have more than 50 people working on the development and production of our bikes.



SUMMARY



P.18 -
LUNDI 26
PRACTICAL URBAN



P.26 -
FRIDAY 27
SPORTY URBAN



P.34 -
SAMEDI 28
VERSATILE TREKKING



P.44 -
SAMEDI 27 XROAD
MULTI-PURPOSE
ROAD / ALL TERRAIN



P.56 -
DIMANCHE 28
LEISURE OR
PERFORMANCE
ROAD



P.62 -
SAMEDI 27
RECREATIONAL MTB



P.108 -
SPEED
THE ULTIMATE RIDE



P.114 -
MERCREDI 12
BEGINNER KIDS



WHAT MAKES OUR BIKES UNIQUE



Ahhhh...the famous Moustache handlebar... where it all started!

Invented by our ancestors, we've updated it and given it a new, unique design. This design has an essential function: it offers a natural riding position for improved comfort. We developed more than 4 different variations, each with small angle differences, until we found the perfect shape. Like our frames, it's made from 6061 alloy, and it also gets the same thermal treatments for maximum resistance.

There are two versions:

// A high-rise city version for our Lundi 26. The riding position is extremely comfortable, with a straight back and the best field of vision.

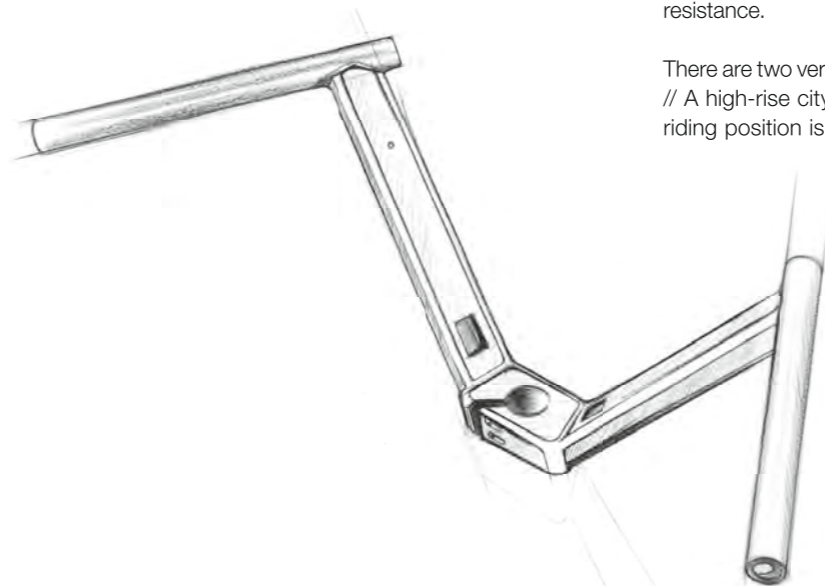

// A touring or trekking version that has less rise, for a more sportive position better suited for longer rides.

We're warning you though, once you try it, you'll never want anything else

At Moustache, we've never really liked mudguards... They're never positioned correctly, they always move, and they're rarely aesthetic... So we decided to start from scratch and develop our own mudguards!

The exclusive Moustache mudguards are tubular and, therefore, very stiff, yet still very lightweight! And they are concentric to the wheel, so it's easier on your eyes too. We developed three exclusive profiles. The guards are extruded and then bent to adapt to the size of the wheel.

A mudguard may appear simple, but it was actually a complex development. But we think you'll agree that it was worth it.



WHY ?

It's the strong belief that performance, quality and service are the foundation of any bicycle. Our partnership with Bosch is based on these same values. Bosch is currently the most developed and efficient system that exists... and it's produced in Europe.

ACTIVE LINE PLUS

Driving pleasure at its best! The new Bosch Active Plus motor, ultra-natural, quiet, lightweight and reliable ensures even more driving pleasure.

The maximum torque of up to 50 Nm offers progressive acceleration and ideal assistance for city rides or tours! Absence of friction allows to exceed the cutting speed of 25 km/h without even realizing it! Just awesome!

PERFORMANCE LINE CRUISE

Dynamic and sporty assistance up to 63 Nm gives you more power from the start and powerful driving in all situations.

PERFORMANCE LINE CX

With its maximum torque of up to 75 Nm, the Performance Line CX offers a powerful motor for demanding riders. In eMTB mode, the cyclist always has the necessary power at the right time. Benefit from a perfectly dosed support of up to 300% with incredible dynamic and unique traction.

eMTB MODE

A mode for eMountain Bikers, eMTB mode replaces the current Sport mode in the Performance Line CX range and varies between Tour and Turbo support modes. Thanks to a maximum torque of up to 75 Nm, the motor dynamically boosts the cyclist's own power

between 120% and 300%. Depending on the pedaling power, the progressive assistance automatically adapts to each way of pedaling. Without changing mode, the motor assists by providing the ideal power from the lowest pedaling frequencies. Starting on steep slopes and crossing technical sections becomes

a child's play. For natural pedaling sensations and maximum performance on your favorite singletracks.



SYSTEM BOSCH ACTIVE LINE PLUS

Efficient and progressive. Perfect for daily use.



SYSTEM BOSCH PERFORMANCE LINE CRUISE

Powerful and sporty.



SYSTEM BOSCH PERFORMANCE LINE CX

High torque and sporty.



	ASSISTANCE	TORQUE		ASSISTANCE	TORQUE		ASSISTANCE	TORQUE
ECO	40 %	35 Nm		50 %	40 Nm		50 %	40 Nm
Tour	100 %	40 Nm		120 %	50 Nm		120 %	50 Nm
Sport	170 %	45 Nm		190 %	55 Nm		210 %	60 Nm
Turbo	250 %	50 Nm		275 %	63 Nm		300 %	75 Nm
Nominal continuous rated power according to EN 15194	250W			250W			250W	
Max. mechanical power @ cadence	415W @78rpm			570W @88rpm			600W @80rpm	

AUTONOMY

The data reported here are realistic values measured under the conditions of use detailed below.

For even more precision and personalized results, you can refer to the Bosch online simulator (see page on the right).

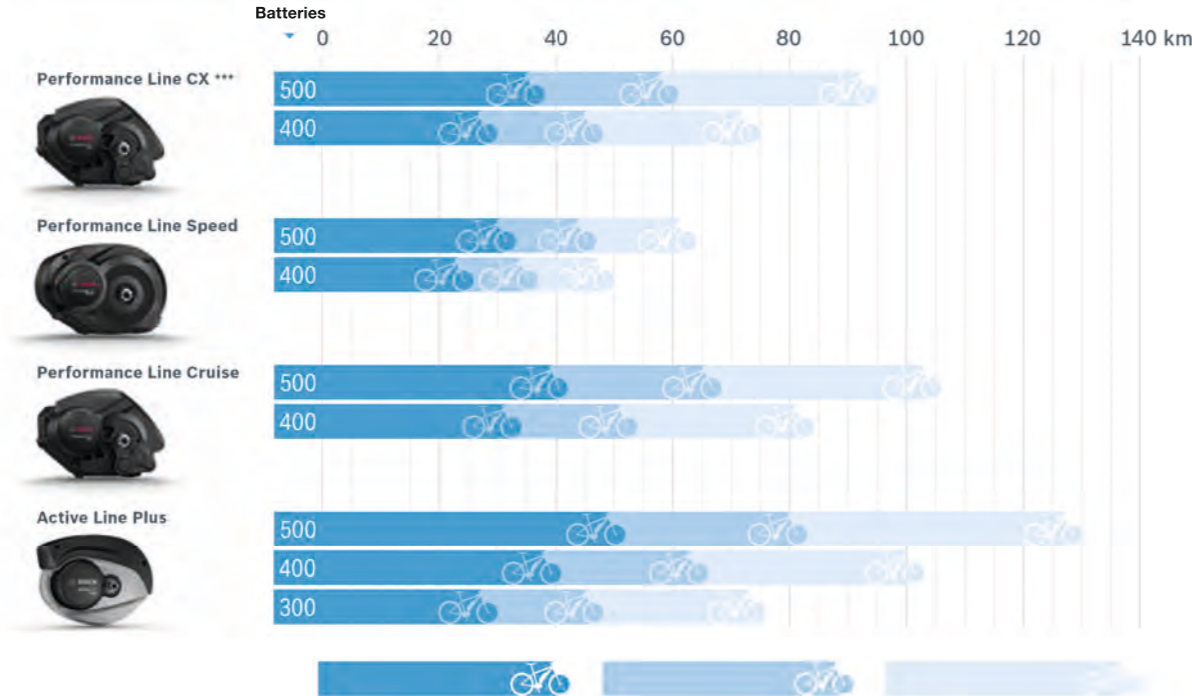

	Difficult conditions*	Favourable conditions*	Ideal conditions**/**
Terrain type	Low mountain ranges	Hilly	Some inclines
Ø-Speed ca.			
Cruise (25 km/h)	18 km/h	21 km/h	24 km/h
Speed (45 km/h)	28 km/h	31 km/h	34 km/h
Wind conditions	Moderate wind	Slight wind	Calm
Cadence	70-90 rpm	50-70 rpm	70-90 rpm
Surface	Dirt tracks and off-road trails	Mainly gravel and paved forest paths	Predominantly smooth asphalt
Tyre Tread	MTB tyres	Trekking tyres	Trekking tyres
Rider weight (Total weight = Rider + bike and luggage)	115 kg	105 kg	95 kg
Starting up frequency	Bike tour with regular starting up	Bike tour with frequent breaks	Bike tour with few breaks
Gears	Derailleur system	Derailleur system	Derailleur system
Type of bicycle	Touring bike / MTB	Touring bike / MTB	Touring bike / MTB
Bosch eBike system	Drive unit, battery and Intuvia	Drive unit, battery and Intuvia	Drive unit, battery and Intuvia

* The ranges are typical values of the new batteries, which may decrease if one of the conditions listed above deteriorates.
 ** No additional connected electronic components, e.g. light.
 *** eMTB mode was not taken into account when calculating these ranges.



Autonomy is extremely variable. It is influenced by many parameters: the type of engine, battery, bike, position, user weight, elevation, type of terrain, wind, tires, gear shifting management, etc... The

data validated in laboratory are sometimes distant from the real conditions. Bosch has therefore developed a very precise simulator that can calculate the autonomy of your bike according to all

these parameters and your use. Perfect to choose the capacity of your battery when several options are available. You can find this simulator on our website or at:

www.bosch-ebike.com/en/service/range-assistant/

INTEGRATE A STANDARD BATTERY

HIDDEN POWER! For this crazy project, the challenge was not only to integrate the battery, but also to minimize volumes. We had to optimize every angle, edge and millimetre. We also had to exceed the limits of hydroforming techniques by increasing the pressures beyond possible to control each cm² of tube.



INTERCHANGEABILITY, AVAILABILITY, COMPATIBILITY

The key to our already successful Hidden Power concept is the use of a standard Bosch battery that can be easily swapped with the largest number of bikes on the market. For example, when two people with different morphologies commit to long rides, how easy is it to be able to exchange the battery between the two bikes mid-ride to balance the autonomies.

This also opens up the possibility of going on vacation abroad without its battery and to rent one on the spot for example. And what is more reassuring in terms of service level than having a standard product and not a specific one.



EASY TO USE

The battery has a practical handle, is easy to install, easy to extract from the top, easy to carry.



PROTECTED

The battery is integrated inside, it is protected from external aggressions and mud by an easily removable cover. It is protected from impacts nested inside the reinforced aluminium tube.



STIFFNESS

Frame design, in particular the down tube, provides a great rigidity and solidity to the frame. It is thanks to the facets and edges of the tube as well as to the optimized cutting, reduced to the maximum that this positive result is obtained.



CENTRE OF GRAVITY

The light battery, only 2.6 kg, very short, positioned at the lowest, positively influences the positioning of the centre of gravity and dynamic behaviour.



POSSIBILITY TO CARRY A 2ND BATTERY

You may already have a second battery, 300, 400 or 500Wh. You can continue using it and take it with you if you commit to endless Alpine rides.

LUNDI 26

PRACTICAL URBAN

We strongly believe that it's possible to change our habits and leave the car in the garage on Monday morning (along with the other days of the week) and go to work, to the market, shopping, or just to discover your city from a new perspective. You may even find yourself having fun!

We wanted to share our own experiences with you,

and that's why we created the Lundi 26, a unique, androgynous and chic e-bike.

We wanted to make it practical, so we developed a step-through frame, and we used 26" balloon tires for additional comfort. The exclusive and ergonomic Moustache handlebar provides a perfect riding position with optimal vision.

Another Moustache innovation: the frame. It has vertical flex to filter vibrations but uses a triple-cavity tube for lateral stiffness, offering maximal stability and safety for unparalleled riding pleasure!

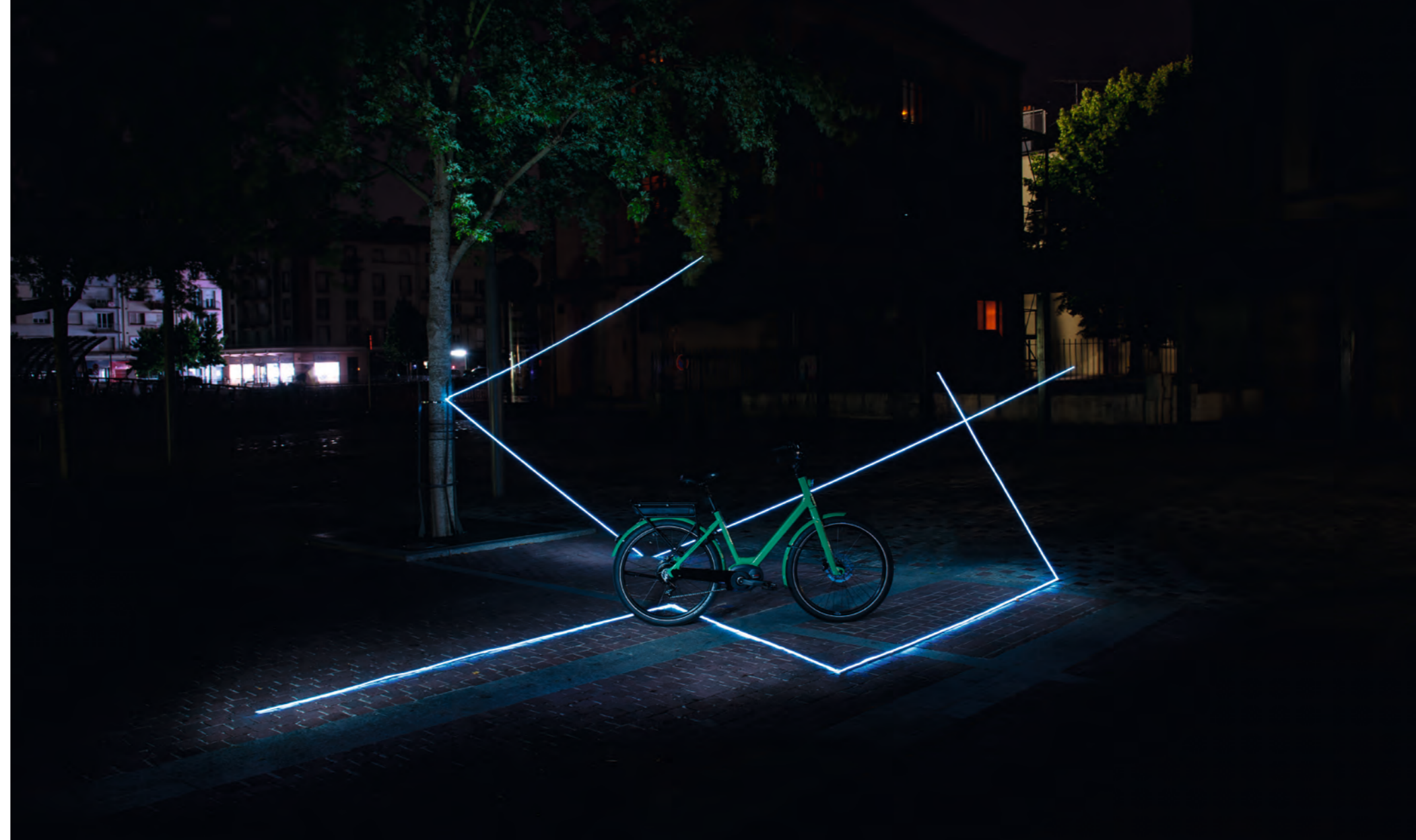



LUNDI 26

- 1 / New color : green réséda.
- 2 / Suspended seatpost on the Lundi 26.3, 26.5, 26.7.
- 3 / Integrated cable routing.
- 4 / Integrated front light.
- 5 / Axa Solid Plus Lock.



Normally it would be mission impossible to make an “open” frame as stiff as a triangular, or diamond, one. Yet we did it!! We developed an exclusive technology for the frame of our Lundi 26 model.

The down tube has three cavities, or the equivalent of three tubes connected to each other. So while the frame has extremely high torsional stiffness, it still offers some vertical flex to absorb vibrations. Torsional, or lateral, stiffness is very important for your safety. This is what keeps the bike from wobbling when you take your hands off the handlebar, when you start pedaling, or at high speeds for example. Having three cavities also means that cable routing can be integrated without compromising the strength or the stiffness of the frame.



LUNDI 26.1



**NEW BOSCH
ACTIVE PLUS**
INTUVIA DISPLAY



DRIVETRAIN 9S
42 X 11/34



BATTERY 300 WH
Autonomy:
see pages 12 to 14



ONE SIZE
T46 (suitable for approximately
1,57 to 1,90m)



AVAILABLE IN 6 COLORS :
black, titanium, white,
petrol, red, green

ICONIC

Our emblematic model, thanks to its unmistakable design!

INNOVATIVE!

Exclusive Aluminium 6061 T4 T6 frame. Triple cavity downtube, stiff laterally, stable and filtering the vertical vibrations. Integrated cables and front light fully embedded in the headtube. Moustache alloy tubular mudguards, super-stable.

COMFORTABLE

Moustache raised handlebar offers an upright and secure position. Suspended seat-post to absorb shocks. Selle Royal Wave saddle, very comfortable. 26x2.35 balloon tires for added comfort and to avoid catching the wheels while crossing tram rails.

PRACTICAL!

Open frame for easy step through. Rear rack with integrated QL3 mounts to attach Moustache Ortlieb panniers in one click. The frame lock under the seatstays allows securing your bike for quick stops.

ULTRA NATURAL, QUIET AND ENERGY SAVING

New Bosch Active Plus system, very natural, compact lightweight and friction-less. Its low consumption provides a generous autonomy from the 300Wh battery.

REASSURING

High position for better visibility. The frame's strong lateral stiffness and the precise 6061 T4 T6 aluminium fork allow for a predictable riding behaviour. Powerful and progressive Shimano hydraulic disk brakes. Efficient and stylish integrated light.

RELIABLE AND EFFICIENT

Shimano 9 Speed 42x11/34 transmission. Moustache tubular aluminium mudguards, ultra-stable. Anti-puncture reinforcements.

ICONIC

Our emblematic model, thanks to its unmistakable design!

INNOVATIVE!

Exclusive Aluminium 6061 T4 T6 frame. Triple cavity downtube, stiff laterally, stable and filtering the vertical vibrations. Integrated cables and front light fully embedded in the headtube. Moustache alloy tubular mudguards, super-stable.

COMFORTABLE

Moustache raised handlebar offers an upright and secure position. Suspended seat-post to absorb shocks. Wide Selle Royal Hertz Gel saddle, very comfortable. 26x2.35 balloon tires for added comfort and to avoid catching the wheels while crossing tram rails.

PRACTICAL!

Open frame for easy step through. Rear rack with integrated QL3 mounts to attach Moustache Ortlieb panniers in one click. The frame lock under the seatstays allows securing your bike for quick stops.

POWERFUL AND ENDURING

Bosch Performance system, dynamic, powerful and with a high torque (63Nm). Provides full support even on the steepest climbs. Ideally combined with the 400Wh battery for optimal autonomy.

REASSURING

High position for better visibility. The frame's strong lateral stiffness and the precise 6061 T4 T6 aluminium fork allow for a predictable riding behaviour. Powerful and progressive Shimano hydraulic disk brakes. Efficient and stylish integrated light.

RELIABLE AND EFFICIENT

Shimano 10 Speed 17x11/36 transmission. Moustache tubular aluminium mudguards, ultra-stable. Anti-puncture reinforcements.

LUNDI 26.3



**NEW BOSCH
PERFORMANCE**
INTUVIA DISPLAY



DRIVETRAIN 10S
17 X 11/36



BATTERY 400 WH
Autonomy:
see pages 12 to 14



ONE SIZE
T46 (suitable for approximately
1,57 to 1,90m)



AVAILABLE IN 6 COLORS :
black, titanium, white,
petrol, red, green

LUNDI 26.5



ICONIC

Our emblematic model, thanks to its unmistakable design!

INNOVATIVE!

Exclusive Aluminium 6061 T4 T6 frame. Triple cavity downtube, stiff laterally, stable and filtering the vertical vibrations. Integrated cables and front light fully embedded in the headtube. Moustache alloy tubular mudguards, super-stable.

COMFORTABLE

Moustache raised handlebar offers an upright and secure position. Suspended seat-post to absorb shocks. Wide Selle Royal Hertz Gel saddle, very comfortable. 26x2.35 balloon tires for added comfort and to avoid catching the wheels while crossing tram rails.

EASY-GOING

The fantastic Nuvinci continuously variable transmission has no equivalent on the market. Changing gear, even when loaded, has never been this easy. Reliable settings and requiring limited maintenance.

PRACTICAL!

Open frame for easy step through. Rear rack with integrated QL3 mounts to attach Moustache Ortlieb panniers in one click. The frame lock under the seatstays allows securing your bike for quick stops.

POWERFUL AND ENDURING

Bosch Performance system, dynamic, powerful and with a high torque (63Nm). Provides full support even on the steepest climbs. Ideally combined with the 400Wh battery for optimal autonomy.

REASSURING

High position for better visibility. The frame's strong lateral stiffness and the precise 6061 T4 T6 aluminium fork allow for a predicatble riding behaviour. Powerful and progressive Shimano hydraulic disk brakes. Efficient and stylish intergrated light.

RELIABLE AND EFFICIENT

Moustache tubular aluminium mudguards, ultra-stable. Anti-puncture reinforcements.



BOSCH PERFORMANCE
INTUVIA DISPLAY



DRIVETRAIN
NUVINCI
continuously variable transmission



BATTERY 400 WH
Autonomy:
see pages 12 to 14



ONE SIZE
T46 (suitable for approximately
1,57 to 1,90m)



AVAILABLE IN 6 COLORS :
black, titanium, white,
petrol, red, green

LUNDI 26.7



ICONIC

Our emblematic model, thanks to its unmistakable design!

INNOVATIVE!

Exclusive Aluminium 6061 T4 T6 frame. Triple cavity downtube, stiff laterally, stable and filtering the vertical vibrations. Integrated cables and front light fully embedded in the headtube. Moustache alloy tubular mudguards, super-stable.

COMFORTABLE

Moustache raised handlebar offers an upright and secure position. Suspended seat-post to absorb shocks. Legendary leather Brooks saddle. 26x2.35 balloon tires for added comfort and to avoid catching the wheels while crossing tram rails.

EASY-GOING

Shimano Alfine 8 speed Di2 electronic shifting system integrated in the rear hub . A simple press allows gear shift. A semi-automatic mode allows automatic downshift when you stop!

PRACTICAL!

Open frame for easy step through. Rear rack with integrated QL3 mounts to attach Moustache Ortlieb panniers in one click. The frame lock under the seatstays allows securing your bike for quick stops.

POWERFUL AND ENDURING:

Bosch Performance system, dynamic, powerful and with a high torque (63Nm). Provides full support even on the steepest climbs. Ideally combined with the 400Wh battery for optimal autonomy.

REASSURING

High position for better visibility. The frame's strong lateral stiffness and the precise 6061 T4 T6 aluminium fork allow for a predicatble riding behaviour. Powerful and progressive Shimano hydraulic disk brakes. Efficient and stylish intergrated light.

RELIABLE AND EFFICIENT

Moustache tubular aluminium mudguards, ultra-stable. Anti-puncture reinforcements.



BOSCH PERFORMANCE
INTUVIA DISPLAY



DRIVETRAIN
ALFINE DI2
electronic, semi-automatic



BATTERY 400 WH
Autonomy:
see pages 12 to 14



ONE SIZE
T46 (suitable for approximately
1,57 to 1,90m)



AVAILABLE IN 6 COLORS :
black, titanium, white,
petrol, red, yellow

FRIDAY 27

SPORTY URBAN

If you're one of those riders who wants a bike that's different and who likes having fun while getting around, we've got the bike for you! We created the Friday because sometimes we all just want to have a little fun.

Think of it as the bicycle version of "casual Friday" at the office. It's fast in the city and practical, sporty and fun once you break out of the urban jungle!

We took great pleasure developing it and designing his hydroformed frame with integrated Bosch battery down to the very last detail. This new frame is using our

exclusive Hidden Power technology both super practical and efficient. Even when integrated, the 400 or 500Wh battery remains easy to install, easy to remove, easy to carry, easy to swap! Yeah!!!! We have increased the practical side by adding a Moustache Quick-Park stem, allowing a 90° turn of the handlebar in a snap. Super practical to park your Friday in an alley way for example!!!

The wider new rear carrier offers an extensive compatibility with most popular child seats on the market along with a reinforced stiffness, thanks to the 2

strong fixing connections to the frame via the tubular mudguard.

Comfort is also on the menu with the addition of new suspension forks creating a Friday range more versatile than ever! The legendary Brooks saddle and 27.5x2.35 balloon tires complement the comfort and elegance at the fullest. The powerful Bosch Performance or Performance CX motors will propel you forward efficiently, spicing up your commutes!

► **Friday 27 Speed :**
page 110





FRIDAY 27

- 1 / Hidden Power exclusive technology. Suspended forks for more comfort and versatility.
- 2 / New wider rear carrier with doubled fixation to the mudguards.
- 3 / New injected ABS chain cover! Stable and strong!



New hydro-formed frame with integrated Bosch battery. This new frame is based on our exclusive Hidden Power technology, ultra-convenient and high performance. Even integrated, the standard 400 or 500Wh battery is easy to install, easy to remove, easy to carry, easy to exchange!

Placed at the lowest, the very short and light battery, only 2.6 kg, positively influences the positioning of the centre of gravity and dynamic behaviour. The offset between the chain stays and the top tube makes it possible to optimize the dispersion of the vibrations and therefore the comfort.

Comfort reinforced by the presence of a suspended seatpost and fork... and the legendary Brooks saddle!

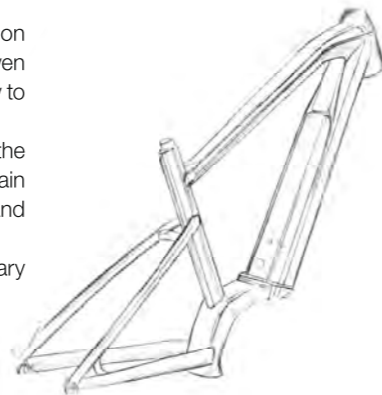

- 4 / Quick park Stem: to save space in a snap! Only a few seconds to turn the handlebar 90° and save 50% storing space.



FRIDAY 27.3



**BOSCH
PERFORMANCE**
INTUVIA DISPLAY



**DRIVETRAIN
DEORE 10S**
17 X 11/36



BATTERY 400 WH
Autonomy:
see pages 12 to 14



SIZE
S41 (1,50 to 1,65 m)
M47 (1,68 to 1,83 m)
L53 (1,81 to 1,95 m)



Suntour XCM ATB fork

INNOVATIVE!

New 6061 T4 T6 aluminium frame. Variable thickness hydroformed tubes. Hidden Power exclusive technology, ultra-practical and high performance. Even integrated, the battery remains easy to install, easy to remove, easy to carry, easy to swap! Awesome for daily use!

PRACTICAL!

The Moustache Quick-Park stem allows turning the handlebar through 90° in a snap. Super practical to stow your Friday in a corridor!!
New wider rear rack. More stable, compatible with child seats and still equipped with integrated QL3 mounts to attach Moustache Ortlieb panniers in one click.

VERSATILE AND COMFORTABLE

Moustache ergonomic handlebar. Balanced position.
New Suntour XCM ATB reinforced fork. 80mm travel.
Balloon tires 27.5x2.35 to filter the asphalt irregularities.
Suspended seat post.
Legendary Brooks saddle!

POWERFUL AND ENDURING

Bosch Performance system, dynamic, powerful and with a high torque (63Nm). Provides a full support even on the steepest climbs.
Ideally combined with the 400Wh battery for an optimal autonomy.

REASSURING

Powerful and progressive Shimano hydraulic disk brakes.
30-lux light for good visibility.

RELIABLE AND EFFICIENT

Shimano 10 Speed 17x11/36 transmission.
Moustache tubular aluminium mudguards, ultra-stable.
Anti-puncture reinforcements.

INNOVATIVE!

New 6061 T4 T6 aluminium frame. Variable thickness hydroformed tubes. Hidden Power exclusive technology, ultra-practical and high performance. Even integrated, the battery remains easy to install, easy to remove, easy to carry, easy to swap! Awesome for daily use!

PRACTICAL!

The Moustache Quick-Park stem allows turning the handlebar through 90° in a snap. Super practical to stow your Friday in a corridor!!
New wider rear rack. More stable, compatible with child seats and still equipped with integrated QL3 mounts to attach Moustache Ortlieb panniers in one click.

VERSATILE AND COMFORTABLE

Moustache ergonomic handlebar. Balanced position.
New Suntour Mobie 25 with aluminium stanchions and hydraulic cartridge with external lock-out, lightweight and very high performance. 63mm travel and 15mm front axle.
Balloon tire 27.5x2.35 to filter the asphalt irregularities.
Suspended seat post.
Legendary Brooks saddle!

POWERFUL AND ENDURING

Bosch Performance system, dynamic, powerful and with a high torque (63Nm). Provides full support even on the steepest climbs.
Equipped with the 500Wh battery for maximum autonomy.

REASSURING

Powerful and progressive Shimano hydraulic disk brakes.
Highly-powerful Supernova light!

RELIABLE AND EFFICIENT:

Shimano SLX 11 Speed 17x11/40 transmission offering wide range.
Moustache tubular aluminium mudguards, ultra-stable.
Anti-puncture reinforcements.

FRIDAY 27.5



**BOSCH
PERFORMANCE**
INTUVIA DISPLAY



**DRIVETRAIN
SLX 11S**
17 X 11/40



BATTERY 500 WH
Autonomy:
see pages 12 to 14



SIZE
S41 (1,50 to 1,65 m)
M47 (1,68 to 1,83 m)
L53 (1,81 to 1,95 m)



Suntour Mobie25 fork, aluminium stanchions, 15mm axle
Supernova front light



INNOVATIVE!

New 6061 T4 T6 aluminium frame. Variable thickness hydroformed tubes. Hidden Power exclusive technology, ultra-practical and high performance. Even integrated, the battery remains easy to install, easy to remove, easy to carry, easy to swap! Awesome for daily use!

PRACTICAL!

The Moustache Quick-Park stem allows turning the handlebar through 90° in a snap. Super practical to stow your Friday in a corridor!!
New wider rear rack. More stable, compatible with child seats and still equipped with integrated QL3 mounts to attach Moustache Ortlieb panniers in one click.

VERSATILE AND COMFORTABLE:

Moustache ergonomic handlebar. Balanced position.
New Suntour Mobie 25 with aluminium stanchions and hydraulic cartridge with external lock-out, lightweight and high performance. 63mm travel and 15mm front axle.
Balloon tire 27.5x2.35 to filter the asphalt irregularities.
Suspended seat post.
Legendary Brooks saddle!

ULTRA POWERFUL AND HIGHLY ENDURING:

Bosch Performance CX, the most powerful and highest torque (75Nm) in the Bosch range. The market reference in terms of support. Equipped with the 500Wh battery for maximum autonomy.

REASSURING

Powerful and progressive Shimano hydraulic disk brakes.
Highly-powerful Supernova light!

RELIABLE AND EFFICIENT

High-end Shimano XT 11 Speed 17x11/40 transmission offering wide range.
Moustache tubular aluminium mudguards, ultra-stable.
Anti-puncture reinforcements.

UNIQUE

Produced as a limited edition, it is equipped with our Moustache waterproof rear pannier made by Ortlieb and installed in one click thanks to QL3 mounts on the rear rack.

FRIDAY 27 LIMITED



**BOSCH
PERFORMANCE CX**
INTUVIA DISPLAY



**DRIVETRAIN
XT 11S**
17 X 11/40



BATTERY 500 WH
Autonomy:
see pages 12 to 14



SIZE
S41 (1,50 to 1,65 m)
M47 (1,68 to 1,83 m)
L53 (1,81 to 1,95 m)



Suntour Mobie25 fork, aluminium stanchions, 15mm axle
Supernova front light
Rear pannier Moustache by Ortlieb

SAMEDI 28

VERSATILE TREKKING

What do you think of a bike made for taking full advantage of weekends, and why not the other days of the week, too? The Samedi 28 is the bike for old-school rides, family rides, leisure rides, or rides that get your heart pumping; to look good while you're riding on city streets or country lanes; slow rides or riding as fast as you can; short rides or riding as long as you can! The first model Samedi 28.1 is using the frame which has build the reputation of the Samedi 28, always declined in 2 versions: Standard or Open frame for easier access. This first level is propelled by the

all new Bosch "Active Plus" providing a "supernatural" assistance both dynamic and energy-efficient with almost no friction. Samedi 28.3 and 28.5 Standard and Open benefit from powerful Bosch Performance and Performance CX systems but most significantly from our exclusive Hidden Power technology!!! The 400 or 500Wh battery is nicely integrated but remain easily accessible or can be swap within seconds with any other similar Bosch battery! Too easy! It also comes with our famous Moustache handlebar, with our innovative tubular

mudguards that are both stiff and lightweight, a wider and more stable rear carrier including QL3 mounts to easily "clic" your compatible panniers on! We hope you'll find just what you're looking for among the different Samedi models: 9, 10 or 11 speed, Standard or Open frame.

► **Samedi 28 Speed :**
page 111





1

SAMEDI 28

- 1 / New Samedi 28 Open frame offering stiffness and stability thanks to the integrated battery and centre of gravity positioned at the lowest. Offset seat tube for minimal step-through height.
- 2 / Hidden Power exclusive Technology! On 28.3 and 28.5!



2



3

- 3 / Schwalbe Citizen tires in 700x47 section on the 28.3 and 28.5. New wider mudguards with doubled fixation to the rear carrier for more stiffness and security. New wider rear carrier, compatible with all child seat clamp-on mounts.
- 4 / Bosch Active Plus motor on 28.1.
- 5 / New injected ABS chain cover! Stable and strong!

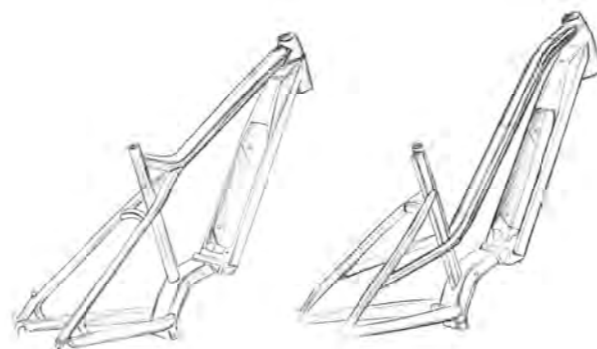

4



5

New hydro-formed frame with integrated Bosch battery. This new frame is based on our exclusive Hidden Power technology, ultra-convenient and high performance. Even integrated, the standard 400 or 500Wh battery is easy to install, easy to remove, easy to carry, easy to exchange! Placed at the lowest, the very short and light battery, only 2.6 kg, positively influences the positioning of the centre of gravity and dynamic behaviour. Made using an aeronautical quality alloy from the 6061 series, the tubes are hydroformed. This is possible thanks to a special technology that

injects high-pressure water into the frame tubes so that they take the shape of the molds. This procedure allows for a greater control of the form and thickness of the tubes, resulting in superior quality and optimal performance. The most amazing tube is without a doubt the top tube, made using a single piece. Unlike classic frames, the top tube is attached directly to the seatstays, which support the rear wheel. This creates a rear triangle that is more compact and has more lateral stiffness, while still absorbing vibrations from the rear wheel through the upper tube (instead of sending them towards the saddle).



SAMEDI 28.1



PERFORMANCE AND ELEGANCE!
6061 T4 T6 aluminium frame, variable thickness hydroformed tubes and polished welds. Technology and aesthetics join forces on well balanced and dynamic geometry.

VERSATILE AND COMFORTABLE
The specific frame construction helps rear wheel vibrations to disperse throughout the top tube. Suntour NEX fork offering 63mm travel, adjustable stem, Selle Royal Wave ergonomic saddle, low rolling resistance tires 700x37.

ULTRA NATURAL, QUIET AND ENERGY SAVING
New Bosch Active Plus system, very natural, compact lightweight and frictionless. Its low consumption provides generous autonomy from the 300Wh battery. Available in 400Wh for increased flexibility.

PRACTICAL!
The adjustable stem fits your exact needs in terms of position.
New wider rear rack. More stable and still equipped with integrated QL3 mounts to attach Moustache Ortlieb panniers in one click.

REASSURING
The strong frame stiffness provides a very predictable ride.
Powerful and progressive Shimano hydraulic disk brakes.
30-lux light for good visibility.

RELIABLE AND EFFICIENT
Shimano 9 Speed 42x11/36 transmission.
Moustache tubular aluminium mudguards, ultra-stable.



SAMEDI 28.1 OPEN



NEW BOSCH ACTIVE PLUS
PURION DISPLAY

DRIVETRAIN ALTUS 9S
42 X 11/36

BATTERY 300 WH OR 400 WH
Autonomy:
see pages 12 to 14

SIZE
S41 (1,55 to 1,70 m)
L48 (1,68 to 1,83 m)

Adjustable Stem

NEW BOSCH ACTIVE PLUS
PURION DISPLAY

DRIVETRAIN ALTUS 9S
42 X 11/36

BATTERY 300 WH OR 400 WH
Autonomy:
see pages 12 to 14

SIZE
S41 (1,55 to 1,70 m)
M47 (1,68 to 1,83 m)
L53 (1,81 to 1,95 m)

Adjustable Stem

SAMEDI 28.3



INNOVATIVE AND ELEGANT!

New 6061 T4 T6 aluminium frame. Variable thickness hydroformed tubes. Hidden Power exclusive technology, ultra-practical and high performance. Even integrated, the battery remains easy to install, easy to remove, easy to carry, easy to swap! Awesome for daily use!

VERSATILE AND COMFORTABLE

The specific frame construction helps rear wheel vibrations to disperse throughout the top tube. The specific Moustache handlebar provides an ideal hand position.

Suntour NEX fork, 63mm travel, Selle Royal Shadow+ ergonomic saddle. Low rolling resistance tires 700x47 with higher volume to enhance the comfort level.

POWERFUL AND ENDURING

Bosch Performance system, dynamic, powerful and with a high torque (63Nm). Provides full support even on the steepest climbs. Ideally combined with 400Wh or 500Wh battery.

PRACTICAL!

Standard battery, easy to manipulate and interchangeable.

New wider rear rack. More stable, compatible with child seats and still equipped with integrated QL3 mounts to attach Moustache Ortlieb panniers in one click.

REASSURING

The strong frame stiffness and low center of gravity provide a very predictable ride. Powerful and progressive Shimano hydraulic disk brakes. 180mm front rotor. 30-lux light for good visibility.

RELIABLE AND EFFICIENT

Shimano 10 Speed 17x11/36 transmission. Moustache tubular aluminium mudguards, ultra-stable. Anti-puncture reinforcements.



SAMEDI 28.3 OPEN



BOSCH PERFORMANCE
INTUVIA DISPLAY



DRIVETRAIN DEORE 10S
17 X 11/36



BATTERY 400 WH OR 500 WH
Autonomy:
see pages 12 to 14



SIZE
S41 (1,55 to 1,70 m)
M47 (1,68 to 1,83 m)
L53 (1,81 to 1,95 m)



AXA Solid Plus integrated lock
Suspended seatpost
700x47 tires



BOSCH PERFORMANCE
INTUVIA DISPLAY



DRIVETRAIN DEORE 10S
17 X 11/36



BATTERY 400 WH OR 500 WH
Autonomy:
see pages 12 to 14



SIZE
S39 (1,49 to 1,61 m)
M45 (1,59 to 1,76 m)
L51 (1,74 to 1,90 m)



AXA Solid Plus integrated lock
Suspended seatpost
700x47 tires

SAMEDI 28.5



INNOVATIVE AND ELEGANT!

New 6061 T4 T6 aluminium frame. Variable thickness hydroformed tubes. Hidden Power exclusive technology, ultra-practical and high performance. Even integrated, the battery remains easy to install, easy to remove, easy to carry, easy to swap! Awesome for daily use!

VERSATILE AND COMFORTABLE

The specific frame construction helps rear wheel vibrations to disperse throughout the top tube. The specific Moustache handlebar provides an ideal hand position.

Suntour NEX fork, hydraulic with external lock-out, 63mm travel, Selle Royal Shadow+ ergonomic saddle. Low rolling resistance tires 700x47 with higher volume to enhance the comfort level.

POWERFUL AND ENDURING

Bosch Performance system, dynamic, powerful and with a high torque (63Nm). Provides full support even on the steepest climbs. Equipped with 500Wh battery for maximum autonomy.

PRACTICAL!

Standard battery, easy to manipulate and interchangeable. New wider rear rack. More stable, compatible with child seats and still equipped with integrated QL3 mounts to attach Moustache Ortlieb panniers in one click.

REASSURING

The strong frame stiffness and low center of gravity provide a very predictable ride. Powerful and progressive Shimano hydraulic disk brakes. 180mm front rotor. 80-lux light for incredible visibility.

RELIABLE AND EFFICIENT

Shimano SLX 11 Speed 17x11/40 transmission with wide range to climb the toughest hills with ease. Moustache tubular aluminium mudguards, ultra-stable. Anti-puncture reinforcements.



SAMEDI 28.5 OPEN



**BOSCH
PERFORMANCE**
INTUVIA DISPLAY



**DRIVETRAIN
SLX 11S**
17 X 11/40



BATTERY 500 WH
Autonomy:
see pages 12 to 14



SIZE
S41 (1,55 to 1,70 m)
M47 (1,68 to 1,83 m)
L53 (1,81 to 1,95 m)



Selle Royal Shadow+
Gel saddle
Spanninga 80-lux
front light



**BOSCH
PERFORMANCE**
INTUVIA DISPLAY



**DRIVETRAIN
SLX 11S**
17 X 11/40



BATTERY 500 WH
Autonomy:
see pages 12 to 14



SIZE
S39 (1,49 to 1,61 m)
M45 (1,59 to 1,76 m)
L51 (1,74 to 1,90 m)



Selle Royal Shadow+
Gel saddle
Spanninga 80-lux
front light

SAMEDI 27 XROAD

MULTI-PURPOSE ROAD / ALL TERRAIN

“One for all and everything’s possible!” That could be Samedi 27 Xroad’s motto.

We were constantly being asked for a bike for urban use, the same bike for touring, and the same again for occasional mountain bike use! Not easy! So, for the Samedi 27 Xroad, we took advantage of the potential of 27.5" wheels and Hutchinson Python tires, which roll well but provide good comfort and traction thanks to their many small studs. Equipped with a mud guard, QL3-compatible rear rack, kickstand and high-performance lighting, Samedi 27 Xroad has everything it

needs for efficient everyday use.

Like on the Samedi 28 and Friday 27, the wider rear rack facilitates the assembly of a clamp-on child seat. The range is growing this year and sees the launch of our new hydroformed frame with integrated Bosch battery on Xroad 3, 5 and 7. This new Standard or Open frame is using our exclusive Hidden Power technology both super practical and efficient. Even when integrated, the 400 or 500Wh battery remains easy to install, easy to remove, easy to carry, easy to swap!

Great for every day use, to go on a weekend ride or even to challenge the highest mountains thanks to his super

powerful Bosch Performance and Performance CX systems associated with wide range gearing transmissions.

Xroad 1 is using the all new Bosch Active Plus system proposing an ultra quiet and very natural support.

Samedi 27 Xroad, It’s up to you to find out how far it can go... or how far you can go! ;-D





SAMEDI 27 XROAD

- 1 / Hidden Power exclusive technology. On 27.3, 27.5 and 27.7!
- 2 / New Suntour forks, stiffer, more travel (80mm) and better tire clearance.

- 3 / New wider mudguards using triple cavity structure. New wider rear carrier with doubled fixation to the mudguards.
- 4 / New Bosch Active Plus motor on 27.1.

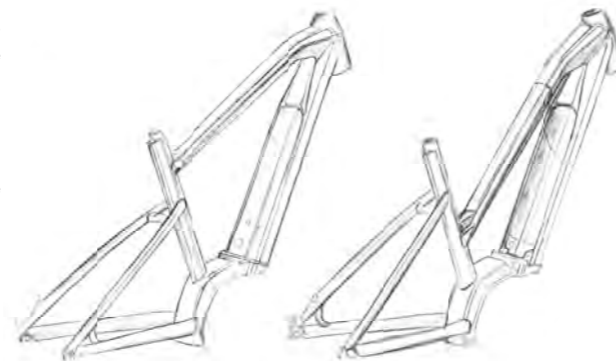

New hydroformed frame with integrated Bosch battery. This new frame is based on our exclusive Hidden Power technology, ultra-convenient and high performance. Even integrated, the standard 400 or 500Wh battery is easy to install, easy to remove, easy to carry, easy to swap! Placed at the lowest, the very short and light battery, only 2.6 kg, positively influences the positioning of the centre of gravity and dynamic behaviour. Made using an aeronautical quality alloy from the 6061 series, the tubes are

hydroformed. This is possible thanks to a special technology that injects high-pressure water into the frame tubes so that they take the shape of the molds. This procedure allows for a greater control of the form and thickness of the tubes, resulting in superior quality and optimal performance. The offset between the chain stays and the top tube creates a compact and dynamic rear triangle while making it possible to optimize the dispersion of the vibrations and therefore the comfort.

SAMEDI 27 XROAD 1



ULTRA VERSATILE

The market leader when it comes to versatility, equally comfortable in the city and off-road thanks to its design and wise components selection.

PERFORMING!

6061 T4 T6 aluminium frame, extruded tubes with variable thickness and polished welds. Light and stiff. Balanced geometry.

COMFORTABLE

Suntour XCM ATB reinforced fork, 80mm travel. Multipurpose tires 27,5x2,15 with micro-knobs, comfortable, fast rolling with grip for all-terrain conditions.

The specific Moustache handlebar provides an ideal hand position.

Selle Royal Wave ergonomic saddle.

ULTRA NATURAL, QUIET AND ENERGY SAVING

New Bosch Active Plus system, very natural, compact lightweight and frictionless. Its low consumption provides a 60 to 140km autonomy with the 400Wh battery.

PRACTICAL!

New wider rear rack. More stable, compatible with child seats and still equipped with integrated QL3 mounts to attach Moustache Ortlieb panniers in one click.

REASSURING

The strong frame stiffness provides a very predictable ride.

Powerful and progressive Shimano hydraulic disk brakes.

30-lux light for good visibility.

RELIABLE AND EFFICIENT

Shimano 9 Speed 42x11/36 transmission. Moustache triple cavity tubular aluminium mudguards, ultra-stable.



SAMEDI 27 OPEN XROAD 1



**NEW BOSCH
ACTIVE PLUS**
PURION DISPLAY



**DRIVETRAIN
ALTUS 9S**
42 X 11/36



BATTERY 400 WH
Autonomy:
see pages 12 to 14



SIZE
S41 (1,55 to 1,70 m)
M47 (1,68 to 1,83 m)
L53 (1,81 to 1,95 m)



Suntour XCM ATB fork,
80mm travel



**NEW BOSCH
ACTIVE PLUS**
PURION DISPLAY



**DRIVETRAIN
ALTUS 9S**
42 X 11/36



BATTERY 400 WH
Autonomy:
see pages 12 to 14



SIZE
S41 (1,55 to 1,70 m)
L48 (1,68 to 1,83 m)



Suntour XCM ATB fork,
80mm travel

SAMEDI 27 XROAD 3



ULTRA VERSATILE

The market leader when it comes to versatility, equally comfortable in the city and off-road thanks to its design and wise components selection.

INNOVATIVE!

New 6061 T4 T6 aluminium frame. Variable thickness hydroformed tubes. Hidden Power exclusive technology, ultra-practical and high performance. Even integrated, the battery remains easy to install, easy to remove, easy to carry, easy to swap! Awesome for daily use!

COMFORTABLE

Suntour XCM ATB reinforced fork, 80mm travel. Multipurpose tires 27,5x2,15 with micro-knobs, comfortable, fast rolling with grip for all-terrain conditions.

The specific Moustache handlebar provides an ideal hand position.

Suspended seat post and Selle Royal Shadow+ ergonomic saddle.

POWERFUL AND ENDURING

Bosch Performance system, dynamic, powerful and with a high torque (63Nm). Provides full support even on the steepest climbs. Ideally combined with 400Wh or 500Wh battery.

PRACTICAL!

Standard battery, easy to manipulate and interchangeable.

New wider rear rack. More stable, compatible with child seats and still equipped with integrated QL3 mounts to attach Moustache Ortlieb panniers in one click.

REASSURING

The strong frame stiffness and low center of gravity provide a very predictable ride.

Powerful and progressive Shimano hydraulic disk brakes.

30-lux light for good visibility.

RELIABLE AND EFFICIENT

Shimano Deore 10 Speed 15x11/36 transmission. Moustache triple cavity tubular aluminium mudguards, ultra-stable.



SAMEDI 27 OPEN XROAD 3



**BOSCH
PERFORMANCE**
INTUVIA DISPLAY



**DRIVETRAIN
DEORE 10S**
15 X 11/36



BATTERY
400 WH OR 500 WH
Autonomy:
see pages 12 to 14



SIZE
S41 (1,55 to 1,70 m)
M47 (1,68 to 1,83 m)
L53 (1,81 to 1,95 m)



Suspended seatpost
30-lux front light



**BOSCH
PERFORMANCE**
INTUVIA DISPLAY



**DRIVETRAIN
DEORE 10S**
15 X 11/36



BATTERY
400 WH OR 500 WH
Autonomy:
see pages 12 to 14



SIZE
S39 (1,49 to 1,61 m)
M45 (1,59 to 1,76 m)
L51 (1,74 to 1,90 m)



Suspended seatpost
30-lux front light

SAMEDI 27 XROAD 5



ULTRA VERSATILE

The market leader when it comes to versatility, equally comfortable in the city and off-road thanks to its design and wise components selection.

INNOVATIVE!

New 6061 T4 T6 aluminium frame. Variable thickness hydroformed tubes. Hidden Power exclusive technology, ultra-practical and high performance. Even integrated, the battery remains easy to install, easy to remove, easy to carry, easy to swap! Awesome for daily use!

COMFORTABLE

Suntour XCM ATB reinforced fork, hydraulic cartridge with external lock-out, 80mm travel. Multipurpose tires 27.5x2.15 with micro-knobs, comfortable, fast rolling and grip for all-terrain conditions. The specific Moustache handlebar provides an ideal hand position. Suspended seat post and Selle Royal Shadow+ Gel ergonomic saddle.

POWERFUL AND ENDURING

Bosch Performance system, dynamic, powerful and with a high torque (63Nm). Provides full support even on the steepest climbs. Equipped with 500Wh battery for maximum autonomy.

PRACTICAL!

Standard battery, easy to manipulate and interchangeable. New wider rear rack. More stable, compatible with child seats and still equipped with integrated QL3 mounts to attach Moustache Ortlieb panniers in one click.

REASSURING

The strong frame stiffness and low center of gravity provide a very predictable ride. Powerful and progressive Shimano hydraulic disk brakes. 180mm front rotor. 80-lux light for incredible visibility.

RELIABLE AND EFFICIENT

Shimano SLX 11 Speed 15x11/42 transmission with wide range to climb the toughest hills with ease. Moustache triple cavity tubular aluminium mudguards, ultra-stable.



SAMEDI 27 OPEN XROAD 5



BOSCH PERFORMANCE
INTUVIA DISPLAY



DRIVETRAIN SLX 11S
15 X 11/42



BATTERY 500 WH
Autonomy:
see pages 12 to 14



SIZE
S39 (1,49 to 1,61 m)
M45 (1,59 to 1,76 m)
L51 (1,74 to 1,90 m)



Selle Royal Shadow+ Gel saddle
Spanninga 80-lux front light
Suntour XCM ATB hydraulic fork
with lock-out



BOSCH PERFORMANCE
INTUVIA DISPLAY



DRIVETRAIN SLX 11S
15 X 11/42



BATTERY 500 WH
Autonomy:
see pages 12 to 14



SIZE
S41 (1,55 to 1,70 m)
M47 (1,68 to 1,83 m)
L53 (1,81 to 1,95 m)



Selle Royal Shadow+ Gel saddle
Spanninga 80-lux front light
Suntour XCM ATB hydraulic fork
with lock-out

SAMEDI 27 XROAD 7



ULTRA VERSATILE

The market leader when it comes to versatility, equally comfortable in the city and off-road thanks to its design and wise components selection.

INNOVATIVE!

New 6061 T4 T6 aluminium frame. Variable thickness hydroformed tubes. Hidden Power exclusive technology, ultra-practical and high performance. Even integrated, the battery remains easy to install, easy to remove, easy to carry, easy to swap! Awesome for daily use!

COMFORTABLE

New Suntour Mobie25 with aluminium stanchions and hydraulic cartridge with external lock-out, lightweight and very high performance. 100mm travel and 15mm front axle. Multipurpose tires 27.5x2.15 with micro-knobs, comfortable, fast rolling and grip for all-terrain conditions. The specific Moustache handlebar provides an ideal hand position. Suntour NCX suspended seat post and Selle Royal Shadow+ Gel ergonomic saddle offers unrivalled comfort.

ULTRA POWERFUL AND HIGHLY ENDURING

Bosch Performance CX, the most powerful and torque (75Nm) in the Bosch range. The market reference in terms of support. Equipped with the 500Wh battery for maximum autonomy.

PRACTICAL!

Standard battery, easy to manipulate and interchangeable. New wider rear rack. More stable, compatible with child seats and still equipped with integrated QL3 mounts to attach Moustache Ortlieb panniers in one click.

REASSURING

The strong frame stiffness and low center of gravity provide a very predictable ride. Powerful and progressive Shimano hydraulic disk brakes. Highly-powerful Supernova light!

RELIABLE AND EFFICIENT

Shimano XT 11 Speed 15x11/42 transmission with wide range to climb the toughest hills with ease. Moustache triple cavity tubular aluminium mudguards, ultra-stable.



SAMEDI 27 OPEN XROAD 7



BOSCH PERFORMANCE CX
INTUVIA DISPLAY



DRIVETRAIN XT 11S
15 X 11/42



BATTERY 500 WH
Autonomy:
see pages 12 to 14



SIZE
S39 (1,49 to 1,61 m)
M45 (1,59 to 1,76 m)
L51 (1,74 to 1,90 m)



Suntour Mobie25 hydraulic fork with lock-out
Ultra-powerful Supernova light
Parallelogram NCX seatpost

DIMANCHE 28

LEISURE OR PERFORMANCE ROAD

If there's one day of the week when you're guaranteed to find cyclists on the road, it's Sunday. Fit or not, young or old, you'll find all kinds of riders enjoying the fresh morning air in their lungs all along the back roads. We made our new Dimanche 28 just for them. Lightweight, dynamic, and streamlined, it will take your weekly rides to a whole new

level. You'll enjoy every inch of concrete so much more when this bike transforms the most grueling climbs into moments of intense riding pleasure.

The new lightweight, very natural, quiet and friction free Bosch Active Plus system has found his best partner to perform at his fullest! Associated with our new ultra

light and stiff frame, the riding pleasure and dynamism are guaranteed!

Now you can enjoy endless rides, relax or sporty, alone or with friends, a new way to live the eBike experience is waiting for you!

► **Dimanche 28 Speed :**
page 112





DIMANCHE 28

- 1 / Continental 700x42 tires, fast rolling and comfortable. Semi-profiled rims.
- 2 / Moustache saddle with anti-slip coating.
- 3 / Possibility of mounting 2 bottle cages.



- 4 / New lighter frame, stiff and dynamic! More sloping for an easier accessibility.
- 5 / Bosch Active Plus motor perfectly matches with the Dimanche 28! Ideal for breaking autonomy records!



Made using an aeronautical quality aluminium from the 6061 series, the tubes are extruded and have thicknesses differentiated according to the constraints. The diagonal tube has a reinforcement under the battery and the upper tube has triple cavities. Thus, a light frame is obtained while being stiff and precise.

The offset between the chain stays and the top tube creates a compact and dynamic rear triangle while making it possible to optimize the dispersion of the vibrations and therefore the comfort.



DIMANCHE 28 FITNESS 1



PERFORMING!

6061 T4 T6 aluminium frame, variable thickness extruded tubes and polished welds. Lightweight and stiff. Well balanced geometry.

DYNAMIC

Lightweight aluminium frame and fork. Semi-profiled rims. Fast-rolling and comfortable 700x42 Continental tires.

ULTRA NATURAL, QUIET AND ENERGY SAVING

New Bosch Active Plus system, very natural, compact lightweight and frictionless. Its low consumption provides a generous autonomy with the 400Wh battery.

PRACTICAL!

Possibility to fit 2 bottle-cages under the top tube. Possibility to add mudguards and rear carrier.

REASSURING

The strong frame stiffness provides a very predictable ride. Powerful and progressive Shimano hydraulic disk brakes.

RELIABLE AND EFFICIENT

Shimano 9 Speed 42x11/36 transmission.



NEW BOSCH ACTIVE PLUS
PURION DISPLAY



DRIVETRAIN ALTUS 9S
42 X 11/36



BATTERY 400 WH
Autonomy:
see pages 12 to 14



SIZE
S41 (1,55 to 1,70 m)
M47 (1,68 to 1,83 m)
L53 (1,81 to 1,95 m)



Possibility to fit 2 bottle-cages

DIMANCHE 28 FITNESS 3



PERFORMING!

6061 T4 T6 aluminium frame, variable thickness extruded tubes and polished welds. Lightweight and stiff. Well balanced geometry.

DYNAMIC

Lightweight aluminium frame and fork. Semi-profiled rims. Fast-rolling and comfortable 700x42 Continental tires.

ULTRA NATURAL, QUIET AND ENERGY SAVING

New Bosch Active Plus system, very natural, compact lightweight and frictionless. Its low consumption provides an incredible autonomy with the 500Wh battery.

PRACTICAL!

Possibility to fit 2 bottle-cages under the top tube. Possibility to add mudguards and rear carrier.

REASSURING

The strong frame stiffness provides a very predictable ride. Powerful and progressive Shimano hydraulic disk brakes.

RELIABLE AND EFFICIENT

Shimano SLX 11 Speed 42x11/40 transmission offering wide range to easily climb the steepest slopes.



NEW BOSCH ACTIVE PLUS
INTUVIA DISPLAY



DRIVETRAIN SLX 11S
42 X 11/40



BATTERY 500 WH
Autonomy:
see pages 12 to 14



SIZE
S41 (1,55 to 1,70 m)
M47 (1,68 to 1,83 m)
L53 (1,81 to 1,95 m)



Possibility to fit 2 bottle-cages

SAMEDI 27

RECREATIONAL MTB /

An eMTB??? That's for lazy people!!! That's what we said originally... And if you still think so, we invite you to visit one of our dealer or test center to discover the potential of those smiling machines!

Thanks to the Bosch Performance or Performance CX systems, the bicycles capacities are multiplied at a level hard to imagine! Climbs are done (almost) as fast as the downhill's and no one will

question the fact that MTB downhill is not a sport!

► **Samedi 27/9 Speed :**
page 113



HIDDEN POWER TECHNOLOGY



HIDDEN
POWER
MOUSTACHE

For this crazy project, our challenge was to integrate a standard Bosch battery, but also to minimize volumes. We stretched our creativity and played with every angle, edge and millimeter, and we pushed hydroforming technology to its limits to create a dynamic aesthetic.

We worked hard at integration and aesthetics, aesthetics that we wanted both neat and dynamic as well as riding feeling, another key point of the project!

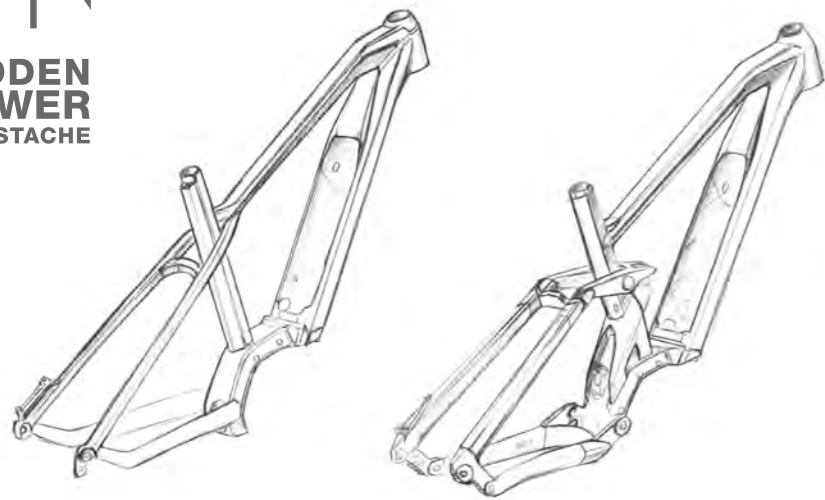

ALUMINIUM FRAMES

Made using an aeronautical quality aluminium from the 6061 series, the tubes are hydroformed. This is possible thanks to a special technology that injects high-pressure water into the frame tubes so that they take the shape of the molds. This procedure allows for a greater control of the form and thickness of the tubes, resulting in superior quality and optimal performance.

GRAVITY CENTRE

Since we started, we have always paid special attention to the bike's centre of gravity. Indeed, it influences behaviour. By lowering it, the overall stability and efficiency of the bicycle is optimized. Already positioned at the lowest, we have been able to lower it and place it backward thanks to the integration of the battery, but also by lowering and placing backward the rear shock and rocker link!



1 / At Moustache, riding sensations, are at the heart of our concerns. To further advance them, we have optimized the neutrality of our suspension platform to not lose a single watt of power. The new compression curve offers a more sensitive suspension at the beginning of the travel and is more progressive for maximum efficiency. The dynamic rebound control system we introduced in 2016 has once again been enhanced and optimized for our new compression curve. It thus offers a lot of grip and allows to keep a good balance even in steep climbs.

2 / Super stiff! The rocker link is mixing aluminium and carbon. It is forged then CNC and finally, 2 carbon reinforcements are glued to boost the rigidity without increasing the weight. Lowered at the maximum, the linkage-rear shock thus contributes to the lowering of the center of gravity.

3 / A Moustache mudguard helps prevents the rear shock from projections.

4 / A SAG indicator is positioned on the left side so you can easily adjust and find the optimum setting! When the rider is on the saddle just position the red o-ring aligned with the indicator.



CARBON

We could have talked of the 890g saved, of the several % increased stiffness, of the high modulus and high strength Toray T700 fibres, the exclusive manufacturing process to control the outside and inside of the tube. We could have written 3 pages, but we preferred to keep it simple:

JUST CARBON

JUST LIGHTER, NICER, FASTER, MORE LIVELY! FOREVER MORE FUN!!!



EXCLUSIVE COMPONENTS
JUST MOUSTACHE



The telescopic seatpost is a must-have accessory! We therefore decided to generalize it on all our Trail and Race as well as on Off 6 and 8. Already very smooth, and perfectly guided, we optimized its operation with a new more effective hydraulic cartridge. It is anodized hard coat for an exemplary longevity. The new ergonomic lever fits perfectly under the thumb and also reduces friction for immediate response. The saddle is a very personal and so important point of contact, especially in electric. With

eMTB in particular, your increased tenfold will allow you to climb steeper climbs. This is why the Moustache saddle is slightly curved in order to offer better support to the pelvis. It is also for this reason that we have used an anti-slip coating, to stay more easily on the front, even in the impossible climbs! This new coating is also more flexible and elastic, providing optimum comfort. Adjustments are often very personal, but, for more efficiency, we recommend a setting with a saddle nose positioned 2 to 4 mm lower than the rear.



Guiding the chain in the best way and avoiding «chain suck», is the mission of our proprietary system. It consists of a flange and two fingers, one nylon and the other stainless steel in order to increase the stiffness and the accuracy of the guide while minimizing wear.



The more you ride a eMTB, the more you improve your skills, the faster you go, the harder you ride! The standard cranks are no longer stiff enough... So we decided to create our own models! They are forged and strengthened in order not to bend from the power of the most enthusiast riders or from your most awesome jumps!



In order to increase rider capabilities, 2 years ago we were the first to create a special 14 tooth sprocket for the Bosch motor... It became the standard. We continued being the first to make use of wide range cassettes, 11/42. Others have followed. We even use 11/46 cassettes on the widest possible range of our bikes so that all benefit from these technological advances! And this year we have again innovated by developing an 11/50 11-speed transmission on a Sram EX1 transmission base. The 11 speeds and the specific staging of the cassette allow to obtain regular variations with less than 20% gap between each gear and widest range. Thus the motor is always in its optimum range of performance. The autonomy is optimized to the maximum, especially in alpine use and in the steepest slopes.

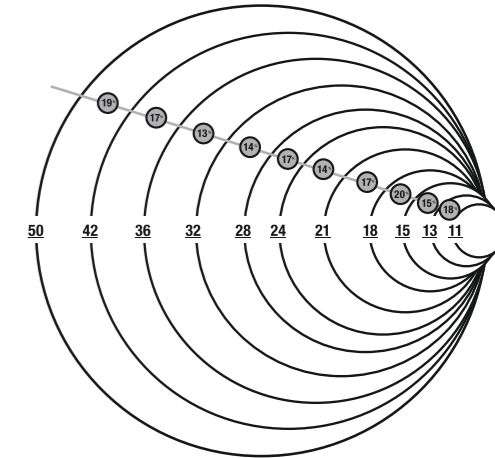

PROGRESSIVE GEAR RATIOS
 Ⓜ Gear variations between cogs
 50 Gog's sizes

EXCLUSIVE COMPONENTS

JUST MOUSTACHE

ALUMINIUM ASYMMETRICAL RIMS 27.5+ JUST MOUSTACHE

Developed specifically for 27.5x2.8 tires, the JUST Moustache rim uses an aluminium 6061-E.

It is welded and heat treated and subsequently microbead blasting to further increase its stability and strength. The sidewalls are specially reinforced to withstand possible impacts.

The asymmetrical profile ensures a homogeneous tension between the two layers of spokes, which guaranty a greater stability and a greater dynamism.

After many tests, we opted for an internal width of

35mm for a perfect match with 2.8 tires.

This is the best balance to maintain a “balloon” tire that does not penalize the steering or when placing the bike on the angle.

Thus the riding remains perfectly natural and dynamic! Just perfect!!! The annular bearing hubs allow to reduce frictions to the lowest once again to serve dynamism and performance!

Why should we waste a single watt of battery with a poor set of wheels? ;-){D



CARBON ASYMMETRICAL RIMS 27.5+ JUST MOUSTACHE

Also developed specifically for 27.5x2.8 tires, the JUST Moustache rim uses a high strength Toray T700 Carbon. Like the aluminium rim, we have achieved the best performance with an internal width of 35mm for a perfect match with 2.8 tires.

This is the best balance to maintain a “balloon” tire that does not penalize the steering or when putting the bike on the angle.

Even more important on a carbon rim, the sidewalls have a higher thickness to withstand the most severe impacts! As for our aluminium rim, the profile is asymmetrical to obtain a homogeneous tension between the two layers of spokes which guaranty a greater stability and a greater dynamism. Here, thanks to the use of carbon, we have even been able to increase the asymmetrical value without compromising the proper balance of the rim.

Thus, we can use only 28 spokes, straight for direct transmission of effort. Double butted to lower weight and inertia. Thanks also to the aluminum nipples that save a few grams.

The hubs are no exception! They are CNC machined with ultra-precise tolerances to allow the annular bearings to express themselves freely.

The free wheel is specific. It has 4 double ratchet pawls for a better engagement and an effort distribution.

Essential! When we know the power and the potential of our eMTB! With a pair of wheels at 1690g, ultra-dynamic, extreme performance are waiting for you!!!

EXCLUSIVE COMPONENTS

JUST MOUSTACHE

30 years riding mountain bikes, 17 years on full suspension and 7 years riding eMTB... it is all these km traveled, all these sensations we find in our Grip Control rear shock!

Unlike a traditional MTB, an eMTB offers a number of possibilities.

You will of course go faster uphill, you will ride much steeper tracks! But you will also go faster on flat ground... and downhill.

With our numerous tests, we discovered the limits of rear shocks available in the market and decided to develop our own solution with specific characteristics to meet our eMTB standards of performance.

Our goal was to ensure an optimal functioning of the bicycle on singletracks, to maintain the balance even on the steepest climbs and to guarantee the rear wheel grip during climbs or downhill.

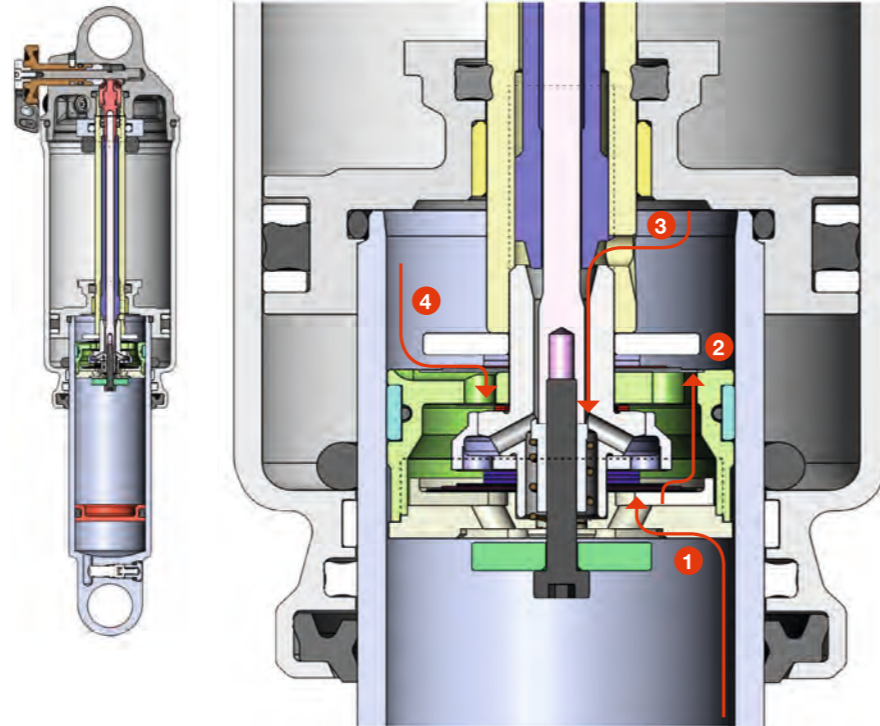

This is why our shock absorber has 4 different circuits:

1 / LOW SPEED COMPRESSION CIRCUIT

The control of the oil flow through this circuit makes it possible **to absorb shocks of low and average intensity and to keep the balance of the bike even on the steepest climbs.**

2 / HIGH-SPEED COMPRESSION CIRCUIT

In the event of a high-impact, the increase in hydraulic load generates the proportional opening of the valves providing **a high level of comfort and efficiency**

3 / LOW SPEED REBOUND CIRCUIT

This is the basic circuit of a rear shock. It slows down the rebound and **keeps the wheel glued to the ground.** Adjustable via a knob, it allows the speed of return to be adapted to the user's weight. The range is deliberately limited on our shock as we are using a complementary rebound circuit, called "high speed".

4 / HIGH-SPEED REBOUND CIRCUIT

It is this high-speed rebound circuit that plays a key role in the overall functioning of our rear shock by allowing **a dynamic control of the rebound.**

Indeed, depending on impacts intensity, instead of only passing through the rebound needle, oil pressure will more or less open the shims of the high-speed circuit and dynamically regulate the rebound, thus offering **a more constant tire pressure on the ground providing an insane grip to the rear wheel, both uphill and downhill.**

Bike oscillations are much better managed giving a greater balance of the bike and a superior grip on the front wheel!

The generated oil flow also allows **to evacuate the calories** and maintain a reasonable operating temperature and optimal functioning.



NEW GRIP CONTROL ULTIMATE REAR SHOCK

This year, we have declined our rear shock in an even more efficient Grip Control Ultimate version. Indeed, the body and the shaft undergo a specific hard anodized treatment in order to further lower the frictions. Not only are frictions falling to further improve sensitivity and responsiveness, but the lifespan is further increased.

SAMEDI 27 OFF



In the age of the eMTB, one could question the relevance of hardtails... We asked ourselves that question, because our full suspension bikes are so efficient... but we had so much fun with the OFF 4, 6 and 8 that the answer was obvious! YES, 10 times YES! The feeling of contact with the ground is different, more direct! It generates real sensations whether you ride cool or fast! What sensations! What fun!

Thanks to the powerful Bosch Performance CX engine, to the ultra dynamic "emt" mode, to the "Plus" tires, wide handlebars, powerful brakes and dropper seatpost (OFF 6 and 8)! And because we wanted to make it even more accessible, we developed the new OFF 2 model, available in standard or step-through frame while still benefiting our Hidden Power battery integration technology! Upgradeable, you can even

adapt our tubular mudguards and our QL3 compatible rear carrier to widen the field of action.

For the youngest of us, Samedi 26 OFF is using the full potential of the new lightweight Bosch Active Plus engine and his natural support. The ideal bike to get started and enjoy family rides!

Smiling machines more than ever!





ACCESSIBLE!

6061 T4 T6 aluminium frame. Variable thickness hydroformed tubes. Ultra compact frame allowing the youngest to access the eBike world (from approx. 1.35m size). Ideal to get started and enjoy family rides!

COMFORTABLE:

Suntour XCM fork, 80mm travel.
Versatile 26" tires.
Moustache ergonomic saddle with anti-slip material.

**ULTRA NATURAL,
QUIET AND ENERGY SAVING**

New Bosch Active Plus system, very natural, compact, lightweight and friction-less. Its low consumption provides a generous autonomy from the 300Wh battery.

RELIABLE AND EFFICIENT

Shimano Deore 9 Speed 34x11/36 transmission.

SAMEDI 26 OFF



**NEW BOSCH
ACTIVE PLUS**
PURION DISPLAY



**DRIVETRAIN
ALTUS 9S**
34 X 11/36



BATTERIE 300 WH
Autonomy:
see pages 12 to 14



SIZE
XS35 (1,33 to 1,50 m)



XS optimised geometry
Suntour XCM fork,
80mm travel

SAMEDI 27 OFF 2



INNOVATIVE!

New 6061 T4 T6 aluminium frame. Variable thickness hydroformed tubes. Hidden Power exclusive technology, ultra-practical and high performance.

EVOLUTION

Engineered for all around eMTB, it can evolve towards mixed use with the addition of our tubular mudguards and our rear rack!

COMFORTABLE

Suntour XCM ATB reinforced, 100mm travel. Multipurpose tires 27.5x2.15 with micro-knobs. Suspended seat post and Selle Royal Shadow+ ergonomic saddle.

EASY TO USE

Even integrated, the battery remains easy to install, easy to remove, easy to carry, easy to swap! Awesome for long distance with an extra battery for example!

POWERFUL AND ENDURING

Bosch Performance system, dynamic, powerful and with high torque (63Nm). Provides full support even on the steepest climbs. Ideally combined with 400Wh or 500Wh battery.

REASSURING

The strong frame stiffness and low center of gravity provide a very predictable ride. Powerful and progressive Shimano hydraulic disk brakes.

RELIABLE AND EFFICIENT

Shimano Deore 9 Speed 14x11/36 transmission.



SAMEDI 27 OFF 2 OPEN



**BOSCH
PERFORMANCE**
PURION DISPLAY



**DRIVETRAIN
ACERA 9S**
14 X 11/36



BATTERY
400 WH OR 500 WH
Autonomy:
see pages 12 to 14



SIZE
S41 (1,55 to 1,70 m)
M47 (1,68 to 1,83 m)
L53 (1,81 to 1,95 m)



UPGRADEABLE :
mudguards and rear rack
compatibles
Suntour XCM ATB fork,
100mm travel



**BOSCH
PERFORMANCE**
PURION DISPLAY



**DRIVETRAIN
ACERA 9S**
14 X 11/36



BATTERY
400 WH OR 500 WH
Autonomy:
see pages 12 to 14



SIZE
S39 (1,49 to 1,61 m)
M45 (1,59 to 1,76 m)
L51 (1,74 to 1,90 m)



UPGRADEABLE :
mudguards and rear rack
compatibles
Suntour XCM ATB fork,
100mm travel

SAMEDI 27 OFF 4



INNOVATIVE!

New 6061 T4 T6 aluminium frame. Variable thickness hydroformed tubes. Hidden Power exclusive technology, ultra-practical and high performance.

PERFORMING

New playful geometry for maximum pleasure! The frame architecture offers one of the lowest centres of gravity on the market for amazing efficiency. Suntour XCR 34 fork, hydraulic cartridge with external lock-out and rebound adjustment. Boost standard and Qlock 15mm for stiff and precise steering. 130mm travel. Powerful and progressive Shimano hydraulic disk brakes.

DYNAMIC

27.5+ wheels for maximum efficiency and grip whatever the terrain. Sealed annular bearings hubs for low friction and maximised autonomy. Asymmetric welded rims, Moustache specific 35mm wide, tubeless compatible. Strong 27.5x2.8" Maxxis tires provide grip and dynamism for incredible fun.

EASY TO USE

Even integrated, the battery remains easy to install, easy to remove, easy to carry, easy to swap! Awesome for long distance with an extra battery for example! Moustache ergonomic saddle with anti-slip material to maintain best position when climbing the steepest climbs!

ULTRA POWERFUL AND HIGHLY ENDURING:

Bosch Performance CX, the most powerful and highest torque (75Nm) in the Bosch range. The market reference in terms of support. eMTB mode for enhanced performance in MTB usage. Combined with 400Wh or 500Wh battery for maximum autonomy.

RELIABLE AND EFFICIENT

Shimano SLX 11 Speed 14x11/46 transmission with wide range to climb the steepest hills with ease and enhance the autonomy for endless rides!



BOSCH PERFORMANCE CX
eMTB Mode
PURION DISPLAY



DRIVETRAIN SLX 11S
14 X 11/46



BATTERY 400 WH OR 500 WH
Autonomy:
see pages 12 to 14



SIZE
S40 (1,55 to 1,70 m)
M46 (1,68 to 1,83 m)
L52 (1,81 to 1,95 m)



27.5+ wheels, 27.5x2.8 Maxxis tubeless tires
Suntour XCR 34 Boost fork

INNOVATIVE!

New 6061 T4 T6 aluminium frame. Variable thickness hydroformed tubes. Hidden Power exclusive technology, ultra-practical and high performance.

PERFORMING

New playful geometry for maximum pleasure! The frame architecture offers one of the lowest centres of gravity on the market for amazing efficiency. Suntour Raidon 34 fork, black aluminium stanchions, hydraulic cartridge with external lock-out and rebound adjustments. Boost standard and Qlock 15mm for stiff and precise steering. 130mm travel. Powerful and progressive Magura MT4 hydraulic disk brakes, 180mm rotors.

DYNAMIC

27.5+ wheels for maximum efficiency and grip whatever the terrain. Sealed annular bearings hubs for low friction and maximised autonomy. Asymmetric welded rims, Moustache specific 35mm wide, tubeless compatible. Strong 27.5x2.8" Maxxis tires provide grip and dynamism for incredible fun.

EASY TO USE

Even integrated, the battery remains easy to install, easy to remove, easy to carry, easy to swap! Awesome for long distance with an extra battery for example! Moustache telescopic cartridge seatpost, smooth and efficient, to easily drop your saddle on the most technical trails! Moustache ergonomic saddle with anti-slip material to maintain best position when climbing the steepest climbs!

ULTRA POWERFUL AND HIGHLY ENDURING

Bosch Performance CX, the most powerful and the highest torque (75Nm) in the Bosch range. The market reference in terms of support. eMTB mode for enhanced performance in MTB usage. Equipped with 500Wh battery for maximum autonomy.

RELIABLE AND EFFICIENT

High-end Shimano XT 11 Speed 14x11/46 transmission with wide range to climb the steepest hills with ease and enhance the autonomy for endless rides!

SAMEDI 27 OFF 6



BOSCH PERFORMANCE CX
eMTB Mode
PURION DISPLAY



DRIVETRAIN XT 11S
14 X 11/46



BATTERY 500 WH
Autonomy:
see pages 12 to 14



SIZE
S40 (1,55 to 1,70 m)
M46 (1,68 to 1,83 m)
L52 (1,81 to 1,95 m)



Telescopic seatpost
Suntour Raidon 34 Boost fork
Magura MT4 180 brakes



INNOVATIVE!

New 6061 T4 T6 aluminium frame. Variable thickness hydroformed tubes. Hidden Power exclusive technology, ultra-practical and high performance.

PERFORMING

New playful geometry for maximum pleasure! The frame architecture offers one of the lowest centres of gravity on the market for amazing efficiency.

FOX 34 fork, E-Bike specific, black aluminium stanchions, GRIP hydraulic cartridge with external lock-out and rebound. Boost standard 15x110mm for stiff and precise steering. 140mm travel.

Powerful and progressive Magura MT4 hydraulic disk brakes with differential rotors (Front 200mm and Rear 180mm).

DYNAMIC

27.5+ wheels for maximum efficiency and grip whatever the terrain.

Sealed annular bearings hubs for low friction and maximised autonomy.

Asymetric welded rims, Moustache specific 35mm wide, tubeless compatible. Strong 27.5x2.8" Maxxis tires provide grip and dynamism for incredible fun.

EASY TO USE

Even integrated, the battery remains easy to install, easy to remove, easy to carry, easy to swap! Awesome for long distance with an extra battery for example!

Moustache telescopic cartridge seatpost, smooth and efficient, to easily drop your saddle on the most technical trails!

Moustache ergonomic saddle with anti-slip material to maintain best position when climbing the steepest climbs!

ULTRA POWERFUL AND HIGHLY ENDURING:

Bosch Performance CX, the most powerful and the highest torque (75Nm) in the Bosch range. The market reference in terms of support. eMTB mode for enhanced performance in MTB usage. Equipped with 500Wh battery for maximum autonomy.

RELIABLE AND EFFICIENT

High-end Shimano XTR 11 Speed 14x11/46 transmission with wide range to climb the steepest hills with ease and enhance the autonomy for endless rides!

SAMEDI 27 OFF 8



BOSCH PERFORMANCE CX
eMTB Mode
PURION DISPLAY



DRIVETRAIN XTR 11S
14 X 11/46



BATTERY 500 WH
Autonomy:
see pages 12 to 14



SIZE
S40 (1,55 to 1,70 m)
M46 (1,68 to 1,83 m)
L52 (1,81 to 1,95 m)



FOX 34 Performance fork
Magura MT4 200/180 brakes

SAMEDI 27 TRAIL



A climb is just a descent going the other way ;-D This kind of thing never happens on a Samedi 27 Trail! Uphill or downhill; it's all good!

Launched in 2017, acclaimed by the users and the international media, Samedi 27 Trail is the result of all our experience and our thousands of kilometers on power-assisted mountain bikes. Thanks to our "Hidden Power" exclusive integration technology, the battery is easy to install, easy to remove, easy

to carry, easy to swap! Unbeatable advantage on the most demanding long distance races such as Transvésubienne which the Samedi 27 Trail has ended on the top spot in 2017! Whether you want to perform at racing level or enjoy a great day out riding your favorite trails, the Trail family offers 140mm of front and rear travel, a new more aggressive geometry, a refined progressive kinematic and a Grip Control Evo rear shock whose dynamic rebound

control has been improved and optimized for the "Plus" section tires.

The centre of gravity has been moved down and backward to further improve the dynamism and overall balance of the bike.

With "only" 140 mm of travel, it is accessible and yet amazing in every situation!

Latest innovation: our new carbon rims!!! After having developed our own cranksets, chain guides and

aluminium rims specifically designed for eMTB, this season we have focused our know-how to develop a very high-end wheelset! Specific hub with 4 double ratchets for fast and efficient engagement, 28 flat spokes and a specific 35mm wide carbon rim with reinforced wall to resist the toughest impacts!

Samedi 27 Trail means more fun, more grip, more energy, more driving, more pleasure!



SAMEDI 27 TRAIL 4



INNOVATIVE!

6061 T4 T6 aluminium frame. Variable thickness hydroformed tubes. Hollow tech alu/carbon rocker link. Hidden Power exclusive technology, ultra-practical and high performance.

PERFORMING!

Balanced Trail geometry for easy handling, to go full throttle on the singletracks and slalom between the pine trees!

The frame architecture offers one of the lowest centres of gravity on the market for amazing efficiency.

Grip control Evo rear shock 200x51 with dynamic rebound control for insane grip on the rear wheel and perfectly balanced stability.

140mm travel.

Suntour XCR 34 fork LOR, hydraulic cartridge with external lock-out and rebound adjustments. Boost standard and Qlock 15mm for stiff and precise steering.

130mm travel.

Powerful and progressive Shimano hydraulic disk brakes, 180mm rotors.

DYNAMIC

27.5+ wheels for maximum efficiency and grip whatever the terrain.

Sealed annular bearings hubs for low friction and maximised autonomy.

Asymmetrical welded aluminium rims, Moustache specific 35mm wide, tubeless compatible. Strong 27.5x2.8" Maxxis tires provide grip and dynamism for incredible fun.

EASY TO USE

Even integrated, the battery remains easy to install, easy to remove, easy to carry, easy to swap! Awesome for long distance with an extra battery for example!

Moustache telescopic cartridge seatpost, smooth and efficient, to easily drop your saddle on the most technical trails!

Moustache ergonomic saddle with anti-slip material to maintain best position when climbing the steepest climbs!

ULTRA POWERFUL AND HIGHLY ENDURING

Bosch Performance CX, the most powerful and highest torque (75Nm) in the Bosch range. The market reference in terms of support. eMTB mode for enhanced performance in MTB usage. Combined with 400Wh or 500Wh battery for maximum autonomy.

RELIABLE AND EFFICIENT

Shimano SLX 11 Speed 14x11/46 transmission with wide range to climb the steepest hills with ease and enhance the autonomy for endless rides!

The Moustache chain guide avoids chain drop and "chain suck".



**BOSCH
PERFORMANCE CX**
eMTB Mode
PURION DISPLAY



**DRIVETRAIN
SLX 11S**
14 X 11/46



**BATTERY
400 WH OR 500 WH**
Autonomy:
see pages 12 to 14



SIZE
S40 (1,55 to 1,70 m)
M44 (1,68 to 1,85 m)
L50 (1,83 to 2 m)



Suntour XCR LOR
Boost fork
Telescopic seatpost

SAMEDI 27 TRAIL 4 W



INNOVATIVE!

6061 T4 T6 aluminium frame. Variable thickness hydroformed tubes. Hollow tech alu/carbon rocker link. Hidden Power exclusive technology, ultra-practical and high performance.

OPTIMIZED ACCESSIBILITY!

Narrower handlebar (700mm) and shorter stem (50mm). Very comfortable Selle Royal Shadow+ saddle. Specific suspension settings.

PERFORMING!

Balanced Trail geometry for easy handling, to go full throttle on the singletracks and slalom between the pine trees! The frame architecture offers one of the lowest centres of gravity on the market for amazing efficiency.

Grip control Evo rear shock 200x51 with dynamic rebound control for insane grip on the rear wheel and perfectly balanced stability.

140mm travel.

Suntour XCR 34 fork LOR, hydraulic cartridge with external lock-out and rebound adjustments. Boost standard and Qlock 15mm for stiff and precise steering.

130mm travel.

Powerful and progressive Shimano hydraulic disk brakes, 180mm rotors.

DYNAMIC

27.5+ wheels for maximum efficiency and grip whatever the terrain.

Sealed annular bearings hubs for low friction and maximised autonomy.

Asymmetrical welded aluminium rims, Moustache specific 35mm wide, tubeless compatible. Strong 27.5x2.8" Maxxis tires provide grip and dynamism for incredible fun.

EASY TO USE

Even integrated, the battery remains easy to install, easy to remove, easy to carry, easy to swap! Awesome for long distance with an extra battery for example!

Moustache telescopic cartridge seatpost, smooth and efficient, to easily drop your saddle on the most technical trails!

ULTRA POWERFUL AND HIGHLY ENDURING:

Bosch Performance CX, the most powerful and highest torque (75Nm) in the Bosch range. The market reference in terms of support. eMTB mode for enhanced performance in MTB usage. Combined with 400Wh or 500Wh battery for maximum autonomy.

RELIABLE AND EFFICIENT

Shimano SLX 11 Speed 14x11/46 transmission with wide range to climb the steepest hills with ease and enhance the autonomy for endless rides!

The Moustache chain guide avoids chain drop and "chain suck".



**BOSCH
PERFORMANCE CX**
eMTB Mode
PURION DISPLAY



**DRIVETRAIN
SLX 11S**
14 X 11/46



**BATTERY
400 WH OR 500 WH**
Autonomy:
see pages 12 to 14



SIZE
S40 (1,55 to 1,70 m)
M44 (1,68 to 1,85 m)
L50 (1,83 to 2 m)



Suntour XCR LOR
Boost fork
Telescopic seatpost
Optimized accessibility

SAMEDI 27 TRAIL 6



INNOVATIVE!

6061 T4 T6 aluminium frame. Variable thickness hydroformed tubes. Hollow tech alu/carbon rocker link. Hidden Power exclusive technology, ultra-practical and high performance.

PERFORMING!

Balanced Trail geometry for easy handling, to go full throttle on the singletracks and slalom between the pine trees!
The frame architecture offers one of the lowest centres of gravity on the market for amazing efficiency.
Grip control Evo rear shock 200x51 with dynamic rebound control for insane grip on the rear wheel and perfectly balanced stability. 140mm travel.
Suntour AION 35 RL fork, hydraulic cartridge with external lock-out and rebound adjustments. Boost standard and Qlock 15mm for stiff and precise steering. 140mm travel.
Powerful and progressive Magura MT4 hydraulic disk brakes, double pistons, with differential rotors (Front 200mm and Rear 180mm).

DYNAMIC

27.5+ wheels for maximum efficiency and grip whatever the terrain.
Sealed annular bearings hubs for low friction and maximised autonomy.
Asymmetrical welded aluminium rims, Moustache specific 35mm wide, tubeless compatible. Strong 27.5x2.8" Maxxis tires provides grip and dynamism for incredible fun.

EASY TO USE

Even integrated, the battery remains easy to install, easy to remove, easy to carry, easy to swap! Awesome for long distance with an extra battery for example!
Moustache telescopic cartridge seatpost, smooth and efficient, to easily drop your saddle on the most technical trails!
Moustache ergonomic saddle with material to maintain best position when climbing the steepest climbs!

ULTRA POWERFUL AND HIGHLY ENDURING

Bosch Performance CX, the most powerful and highest torque (75Nm) in the Bosch range. The market reference in terms of support. eMTB mode for enhanced performance in MTB usage. Equipped with 500Wh battery for maximum autonomy.

RELIABLE AND EFFICIENT

High-end Shimano XT 11 Speed 14x11/46 transmission with wide range to climb the steepest hills with ease and enhance the autonomy for endless rides!
The Moustache chain guide avoids chain drop and "chain suck".

Suntour AION 35 RL fork
Magura MT4 200/180 brakes

SIZE
S40 (1,55 to 1,70 m)
M44 (1,68 to 1,85 m)
L50 (1,83 to 2 m)

BATTERY 500 WH
Autonomy:
see pages 12 to 14

DRIVETRAIN XT 11S
14 X 11/46

BOSCH PERFORMANCE CX
eMTB Mode
PURION DISPLAY

SAMEDI 27 TRAIL 8



INNOVATIVE!

6061 T4 T6 aluminium frame. Variable thickness hydroformed tubes. Hollow tech alu/carbon rocker link. Hidden Power exclusive technology, ultra-practical and high performance.

PERFORMING!

Balanced Trail geometry for easy handling, to go full throttle on the singletracks and slalom between the pine trees!
The frame architecture offers one of the lowest centres of gravity on the market for amazing efficiency.
Grip control Ultimate rear shock 200x51 with hard anodized coating for low friction, dynamic rebound control for insane grip on the rear wheel and perfectly balanced stability. 140mm travel.
FOX 34 fork, E-Bike specific, black aluminium stanchions, GRIP hydraulic cartridge with external lock-out and rebound. Boost standard 15x110mm for stiff and precise steering. 140mm travel.
Powerful and progressive Magura MT Trail Sport hydraulic disk brakes, 4 pistons at the front (200mm rotor) and 2 pistons at the rear (180mm rotor), new 1 finger lever.

DYNAMIC

27.5+ wheels for maximum efficiency and grip whatever the terrain.
Sealed annular bearings hubs for low friction and maximised autonomy.
Asymmetrical welded aluminium rims, Moustache specific 35mm wide, tubeless compatible. Strong 27.5x2.8" Maxxis tires provides grip and dynamism for incredible fun.

EASY TO USE

Even integrated, the battery remains easy to install, easy to remove, easy to carry, easy to swap! Awesome for long distance with an extra battery for example!
Moustache telescopic cartridge seatpost, smooth and efficient, to easily drop your saddle on the most technical trails!
Moustache ergonomic saddle with anti-slip material to maintain best position when climbing the steepest climbs!

ULTRA POWERFUL AND HIGHLY ENDURING

Bosch Performance CX, the most powerful and highest torque (75Nm) in the Bosch range. The market reference in terms of support. eMTB mode for enhanced performance in MTB usage. Equipped with 500Wh battery for maximum autonomy.

RELIABLE AND EFFICIENT

High-end Shimano XTR 11 Speed 14x11/46 transmission with wide range to climb the steepest hills with ease and enhance the autonomy for endless rides!
The Moustache chain guide avoids chain drop and "chain suck".

FOX 34 Performance fork
Magura MT Trail Sport brakes :
Front: 4 pistons, 200mm rotors
Rear: 2 pistons, 180mm rotors

SIZE
S40 (1,55 to 1,70 m)
M44 (1,68 to 1,85 m)
L50 (1,83 to 2 m)

BATTERY 500 WH
Autonomy:
see pages 12 to 14

DRIVETRAIN XTR 11S
14 X 11/46

BOSCH PERFORMANCE CX
eMTB Mode
PURION DISPLAY

SAMEDI 27 TRAIL 7

JUST CARBON



INNOVATIVE!
JUST CARBON frame technology, Toray T700 fibers. Variable thickness hydroformed aluminium rear triangle. Light, dynamic and incredibly lively! Hollow tech alu/carbon rocker link. Hidden Power exclusive technology, ultra-practical and high performance.

PERFORMING!
 Balanced Trail geometry for easy handling, to go full throttle on the singletracks and slalom between the pine trees!
 The frame architecture offers one of the lowest centres of gravity on the market for amazing efficiency. Grip control Evo rear shock 200x51 with dynamic rebound control for insane grip on the rear wheel and perfectly balanced stability. 140mm travel. Suntour AION 35 RL fork, hydraulic cartridge with external lock-out and rebound adjustments. Boost standard and Qlock 15mm for stiff and precise steering. 140mm travel. Powerful and progressive Magura MT4 hydraulic disk brakes, double pistons, with differential rotors (Front 200mm and Rear 180mm).

DYNAMIC
 27.5+ wheels for maximum efficiency and grip whatever the terrain. Sealed annular bearings hubs for low friction and maximised autonomy. Asymmetrical welded aluminium rims, Moustache specific 35mm wide, tubeless compatible. Strong 27.5x2.8" Maxxis tires provides grip and dynamism for incredible fun.

EASY TO USE
 Even integrated, the battery remains easy to install, easy to remove, easy to carry, easy to swap! Awesome for long distance with an extra battery for example! Moustache telescopic cartridge seatpost, smooth and efficient, to easily drop your saddle on the most technical trails! Moustache ergonomic saddle with anti-slip material to maintain best position when climbing the steepest climbs!

ULTRA POWERFUL AND HIGHLY ENDURING
 Bosch Performance CX, the most powerful and highest torque (75Nm) in the Bosch range. The market reference in terms of support. eMTB mode for enhanced performance in MTB usage. Equipped with 500Wh battery for maximum autonomy.

RELIABLE AND EFFICIENT
 High-end Shimano XT 11 Speed 14x11/46 transmission with wide range to climb the steepest hills with ease and enhance the autonomy for endless rides! The Moustache chain guide avoids chain drop and "chain suck".

INNOVATIVE!
JUST CARBON frame technology, Toray T700 fibers. Variable thickness hydroformed aluminium rear triangle. Light, dynamic and incredibly lively! Hollow tech alu/carbon rocker link. Hidden Power exclusive technology, ultra-practical and high performance.

PERFORMING!
 Balanced Trail geometry for easy handling, to go full throttle on the singletracks and slalom between the pine trees!
 The frame architecture offers one of the lowest centres of gravity on the market for amazing efficiency. Grip control Ultimate rear shock 200x51 with hard anodized coating for low friction, dynamic rebound control for insane grip on the rear wheel and perfectly balanced stability. 140mm travel. FOX 34 Performance fork, E-Bike specific, black aluminium stanchions, GRIP hydraulic cartridge with external lock-out and rebound. Boost standard 15x110mm for stiff and precise steering. 140mm travel. Powerful and progressive Magura MT Trail Sport hydraulic disk brakes, 4 pistons at the front (200mm rotor) and 2 pistons at the rear (180mm rotor), new 1 finger lever.

DYNAMIC
 27.5+ wheels for maximum efficiency and grip whatever the terrain. Sealed annular bearings hubs for low friction and maximised autonomy. Asymmetrical welded aluminium rims, Moustache specific 35mm wide, tubeless compatible. Strong 27.5x2.8" Maxxis tires provides grip and dynamism for incredible fun.

EASY TO USE
 Even integrated, the battery remains easy to install, easy to remove, easy to carry, easy to swap! Awesome for long distance with an extra battery for example! Moustache telescopic cartridge seatpost, smooth and efficient, to easily drop your saddle on the most technical trails! Moustache ergonomic saddle with anti-slip material to maintain best position when climbing the steepest climbs!

ULTRA POWERFUL AND HIGHLY ENDURING
 Bosch Performance CX, the most powerful and highest torque (75Nm) in the Bosch range. The market reference in terms of support. eMTB mode for enhanced performance in MTB usage. Equipped with 500Wh battery for maximum autonomy.

RELIABLE AND EFFICIENT
 High-end Shimano XTR 11 Speed 14x11/46 transmission with wide range to climb the steepest hills with ease and enhance the autonomy for endless rides! The Moustache chain guide avoids chain drop and "chain suck".

SAMEDI 27 TRAIL 9

JUST CARBON



BOSCH PERFORMANCE CX
 eMTB Mode
 PURION DISPLAY

DRIVETRAIN XTR 11S
 14 X 11/46

BATTERY 500 WH
 Autonomy:
 see pages 12 to 14

SIZE
 S40 (1,55 to 1,70 m)
 M44 (1,68 to 1,85 m)
 L50 (1,83 to 2 m)

FOX 34 Performance fork
 Magura MT Trail Sport brakes :
 Front: 4 pistons, 200mm rotors
 Rear: 2 pistons, 180mm rotors



INNOVATIVE!
“JUST CARBON” frame technology, Toray T700 fibers. Variable thickness hydroformed aluminium rear triangle. Light, dynamic and incredibly lively! Hollow tech alu/carbon rocker link. Hidden Power exclusive technology, ultra-practical and high performance.

PERFORMING!
 Balanced Trail geometry for easy handling, to go full throttle on the singletracks and slalom between the pine trees! The frame architecture offers one of the lowest centres of gravity on the market for amazing efficiency. Grip control Ultimate rear shock 200x51 with hard anodized coating for low friction, dynamic rebound control for insane grip on the rear wheel and perfectly balanced stability. 140mm travel.
 New ultra performing and lightweight Rock Shox RCT3 fork, high and slow speed adjustment for rebound and compression. Boost standard 15x110mm for stiff and precise steering. 140mm travel.
 Formula Cura hydraulic disk brakes, precise, powerful, enduring and progressive for an unmatched feeling.

DYNAMIC
 27.5+ wheels for maximum efficiency and grip whatever the terrain.
 Asymmetrical Moustache **“JUST CARBON”** rims, strong and lightweight, eBike specific, 35mm wide, tubeless compatible.
 CNC aluminium hub with sealed annular bearings for low friction and maximised autonomy. 4 double ratchet and 28 straight double butted flat spokes for optimal transmission.
 Strong 27.5x2.8” Maxxis tires provides grip and dynamism for incredible fun.

EASY TO USE
 Even integrated, the battery remains easy to install, easy to remove, easy to carry, easy to swap! Awesome for long distance with an extra battery for example!
 Moustache telescopic cartridge seatpost, smooth and efficient, to easily drop your saddle on the most technical trails!
 Fizik Gobi carbon saddle, light and comfortable.

ULTRA POWERFUL AND HIGHLY ENDURING
 Bosch Performance CX, the most powerful and highest torque (75Nm) in the Bosch range. The market reference in terms of support. eMTB mode for enhanced performance in MTB usage. Equipped with 500Wh battery for maximum autonomy.

RELIABLE AND EFFICIENT
 High-end Shimano XTR 11 Speed 14x11/46 transmission with wide range to climb the steepest hills with ease and enhance the autonomy for endless rides!
 The Moustache chain guide avoids chain drop and “chain suck”.

SAMEDI 27 TRAIL 11

“JUST CARBON”



BOSCH PERFORMANCE CX
 eMTB Mode
 PURION DISPLAY



DRIVETRAIN XTR 11S
 14 X 11/46



BATTERY 500 WH
 Autonomy:
 see pages 12 to 14



SIZE
 S40 (1,55 to 1,70 m)
 M44 (1,68 to 1,85 m)
 L50 (1,83 to 2 m)



“JUST CARBON” wheels
 Rock Shox Pike RCT3 fork
 Formula Cura 200/200 brakes

SAMEDI 27 RACE



Samedi 27 RACE is the heavy duty version of the TRAIL. With 160mm of travel front and rear, its larger brakes and slacker angles, it allows for a more extreme ride, more "Race" to snap a time on an enduro, or simply to ride full speed on any extreme path, whatever the direction of the slope!

Thanks to the experience of our team, and the feedback

from the test riders who helped develop this bike, we optimized the geometry and suspension settings. It's also because of them that we have decided to fit more aggressive front tires this season and an exclusive EX1 11 speed transmission for best gearing ratio and ultra wide range.

And to challenge the most demanding races, what's best than our new carbon

wheelsets!!! Specific hub with 4 double ratchets for fast and efficient engagement, 28 flat spokes and a specific 35mm wide carbon rim with reinforced sidewalls to resist the toughest impacts!

The ideal bike to win an enduro race - and why not the Mega!



SAMEDI 27 RACE 6



INNOVATIVE!
6061 T4 T6 aluminium frame. Variable thickness hydroformed tubes. Hollow tech alu/carbon rocker link. Hidden Power exclusive technology, ultra-practical and high performance.

PERFORMING!
Dedicated Race geometry to beat the best time at your local track or why not win the Mega!
The frame architecture offers one of the lowest centres of gravity on the market for amazing efficiency.
Grip control Evo rear shock 200x57 with dynamic rebound control for insane grip on the rear wheel and perfectly balanced stability.
160mm travel.
Suntour AION 35 RL fork, hydraulic cartridge with external lock-out and rebound adjustment. Boost standard and Qlock 15mm for stiff and precise steering.
160mm travel.
Ultra powerful and progressive Magura MT5 hydraulic disk brakes, forged aluminium 2 finger levers, 4 pistons, with differential rotors (Front 200mm and Rear 180mm).

DYNAMIC
27.5+ wheels for maximum efficiency and grip whatever the terrain.
Sealed annular bearings hubs for low friction and maximised autonomy.
Asymmetrical welded aluminium rims, Moustache specific 35mm wide, tubeless compatible. Front 27.5x2.8" Maxxis Minion DHF tire for maximum grip and rear 27.5x2.8" Maxxis Rekon for best pedaling efficiency.

EASY TO USE
Even integrated, the battery remains easy to install, easy to remove, easy to carry, easy to swap! Awesome for long distance with an extra battery for example!
Moustache telescopic cartridge seatpost, smooth and efficient, to easily drop your saddle on the most technical trails!
Moustache ergonomic saddle with anti-slip material to maintain best position when climbing the steepest climbs!

ULTRA POWERFUL AND HIGHLY ENDURING
Bosch Performance CX, the most powerful and highest torque (75Nm) in the Bosch range. The market reference in terms of support. eMTB mode for enhanced performance in MTB usage. Equipped with 500Wh battery for maximum autonomy.

RELIABLE AND EFFICIENT
High-end Shimano XT 11 Speed 14x11/46 transmission with wide range to climb the steepest hills with ease and enhance the autonomy for endless rides!
The Moustache chain guide avoids chain drop and "chain suck".

Grip control Evo 160mm rear shock
Suntour AION 35 RL fork 160mm
Magura MT5 brakes, 4 pistons 200/180

INNOVATIVE!
6061 T4 T6 aluminium frame. Variable thickness hydroformed tubes. Hollow tech alu/carbon rocker link. Hidden Power exclusive technology, ultra-practical and high performance.

PERFORMING!
Dedicated Race geometry to beat the best time at your local track or why not win the Mega!
The frame architecture offers one of the lowest centres of gravity on the market for amazing efficiency.
Rock Shox Monarch Plus RC3 Debon air shock 200x57 for aggressive riding.
160mm travel.
New Fox 36 Performance fork, E-Bike specific, black aluminium reinforced stanchions, GRIP hydraulic cartridge with external lock-out and rebound adjustment. Boost standard 15x110mm for stiff and precise steering.
160mm travel.
Ultra powerful and progressive Magura MT5 hydraulic disk brakes, forged aluminium 2 finger levers, 4 pistons, with differential rotors (Front 200mm and Rear 180mm).

DYNAMIC
27.5+ wheels for maximum efficiency and grip whatever the terrain.
Sealed annular bearings hubs for low friction and maximised autonomy.
Asymmetrical welded aluminium rims, Moustache specific 35mm wide, tubeless compatible. Front 27.5x2.8" Maxxis Minion DHF tire for maximum grip and rear 27.5x2.8" Maxxis Rekon for best pedaling efficiency.

EASY TO USE
Even integrated, the battery remains easy to install, easy to remove, easy to carry, easy to swap! Awesome for long distance with an extra battery for example!
Moustache telescopic cartridge seatpost, smooth and efficient, to easily drop your saddle on the most technical trails!
Moustache ergonomic saddle with anti-slip material to maintain best position when climbing the steepest climbs!

ULTRA POWERFUL AND HIGHLY ENDURING
Bosch Performance CX, the most powerful and highest torque (75Nm) in the Bosch range. The market reference in terms of support. eMTB mode for enhanced performance in MTB usage. Equipped with 500Wh battery for maximum autonomy.

RELIABLE AND EFFICIENT
Specific Moustache / Sram EX1 11 Speed 14x11/50 transmission for widest range. Especially developed to climb the steepest hills with appropriate gear range thus enhancing the riding comfort and optimizing the autonomy for endless rides!
The Moustache chain guide avoids chain drop and "chain suck".

SAMEDI 27 RACE 8



BOSCH PERFORMANCE CX
eMTB Mode
PURION DISPLAY

DRIVETRAIN EX1 JUST MOUSTACHE, 11V 14 X 11/50

BATTERY 500 WH
Autonomy: see pages 12 to 14

SIZE
S40 (1,53 to 1,70 m)
M44 (1,68 to 1,85 m)
L50 (1,83 to 2 m)

Rock Shox Monarch Plus rear shock, 160mm
FOX 36 Performance fork, 160mm
Magura MT5 brakes 200/180, 4 pistons

SAMEDI 27 RACE 9

JUST CARBON



INNOVATIVE!
JUST CARBON frame technology, Toray T700 fibers. Variable thickness hydroformed aluminium rear triangle. Light, dynamic and incredibly lively! Hollow tech alu/carbon rocker link. Hidden Power exclusive technology, ultra-practical and high performance.

PERFORMING!
 Dedicated Race geometry to beat the best time at your local track or why not win the Mega!
 The frame architecture offers one of the lowest centres of gravity on the market for amazing efficiency.
 Rock Shox Monarch Plus RC3 Debon air shock 200x57 for aggressive riding. 160mm travel.
 Fox 36 Performance fork, E-Bike specific, black aluminium reinforced stanchions, GRIP hydraulic cartridge with external lock-out and rebound adjustment. Boost standard 15x110mm for stiff and precise steering. 160mm travel.
 Ultra powerful and progressive Magura MT5 hydraulic disk brakes, forged aluminium 2 finger levers, 4 pistons, with differential rotors (Front 200mm and Rear 180mm).





DYNAMIC
 27.5+ wheels for maximum efficiency and grip whatever the terrain.
 Sealed annular bearings hubs for low friction and maximised autonomy.
 Asymmetrical welded aluminium rims, Moustache specific 35mm wide, tubeless compatible. Front 27.5x2.8" Maxxis Minion DHF tire for maximum grip and rear 27.5x2.8" Maxxis Rekon for best pedaling efficiency.

EASY TO USE
 Even integrated, the battery remains easy to install, easy to remove, easy to carry, easy to swap! Awesome for long distance with an extra battery for example!
 Moustache telescopic cartridge seatpost, smooth and efficient, to easily drop your saddle on the most technical trails!
 Moustache ergonomic saddle with anti-slip material to maintain best position when climbing the steepest climbs!

ULTRA POWERFUL AND HIGHLY ENDURING:
 Bosch Performance CX, the most powerful and highest torque (75Nm) in the Bosch range. The market reference in terms of support. eMTB mode for enhanced performance in MTB usage. Equipped with 500Wh battery for maximum autonomy.

RELIABLE AND EFFICIENT
 Specific Moustache / Sram EX1 11 Speed 14x11/50 transmission for widest range. Especially developed to climb the steepest hills with appropriate gear range thus enhancing the riding comfort and optimizing the autonomy for endless rides!
 The Moustache chain guide avoids chain drop and "chain suck"

Rock Shox Monarch Plus rear shock, 160mm
 FOX 36 Performance fork, 160mm
 Magura MT5 brakes 200/180, 4 pistons

- 
BOSCH PERFORMANCE CX
 eMTB Mode
 PURION DISPLAY
- 
DRIVETRAIN EX1 JUST MOUSTACHE,
11V 14 X 11/50
- 
BATTERY 500 WH
 Autonomy:
 see pages 12 to 14
- 
SIZE
 S40 (1,53 to 1,70 m)
 M44 (1,68 to 1,85 m)
 L50 (1,83 to 2 m)

INNOVATIVE!
JUST CARBON frame technology, Toray T700 fibers. Variable thickness hydroformed aluminium rear triangle. Light, dynamic and incredibly lively! Hollow tech alu/carbon rocker link. Hidden Power exclusive technology, ultra-practical and high performance.

PERFORMING!
 Dedicated Race geometry to beat the best time at your local track or why not win the Mega! The frame architecture offers one of the lowest centres of gravity on the market for amazing efficiency.
 Grip control Ultimate rear shock 200x57 with hard anodized coating for low friction, dynamic rebound control for insane grip on the rear wheel and perfectly balanced stability. 160mm travel.
 New Fox 36 Factory fork, Kashima coating, FIT4 hydraulic cartridge, Boost standard 15x110mm for stiff and precise steering. 160mm travel.
 Formula Cura hydraulic disk brakes, precise, powerful, enduring and progressive for an unmatched feeling. 200mm rotors.

DYNAMIC
 27.5+ wheels for maximum efficiency and grip whatever the terrain.
 Asymmetrical Moustache **JUST CARBON** rims, strong and lightweight, eBike specific, 35mm wide, tubeless compatible.
 CNC aluminium hub with sealed annular bearings for low friction and maximised autonomy. 4 double ratchet and 28 straight double butted flat spokes for optimal transmission. Front 27.5x2.8" Maxxis Minion DHF tire for maximum grip and rear 27.5x2.8" Maxxis Rekon for best pedaling efficiency.

EASY TO USE
 Even integrated, the battery remains easy to install, easy to remove, easy to carry, easy to swap! Awesome for long distance with an extra battery for example!
 Moustache telescopic cartridge seatpost, smooth and efficient, to easily drop your saddle on the most technical trails!
 Fizik Gobi carbon saddle, light and comfortable.





ULTRA POWERFUL AND HIGHLY ENDURING
 Bosch Performance CX, the most powerful and highest torque (75Nm) in the Bosch range. The market reference in terms of support. eMTB mode for enhanced performance in MTB usage. Equipped with 500Wh battery for maximum autonomy.

RELIABLE AND EFFICIENT
 Specific Moustache / Sram EX1 11 Speed 14x11/50 transmission for widest range. Especially developed to climb the steepest hills with appropriate gear range thus enhancing the riding comfort and optimizing the autonomy for endless rides!
 The Moustache chain guide avoids chain drop and "chain suck".

SAMEDI 27 RACE 11

JUST CARBON



- 
BOSCH PERFORMANCE CX
 eMTB Mode
 PURION DISPLAY
- 
DRIVETRAIN EX1 JUST MOUSTACHE,
11V 14 X 11/50
- 
BATTERY 500 WH
 Autonomy:
 see pages 12 to 14
- 
SIZE
 S40 (1,53 to 1,70 m)
 M44 (1,68 to 1,85 m)
 L50 (1,83 to 2 m)

Grip Control Ultimate rear shock, 160mm
 FOX 36 Factory fork, 160mm
 Formula Cura 200/200 brakes

SAMEDI 27 LT



To commit strongly in the downhill... and be able to get back up!

With the Samedi 27.5 LT... there's no need to worry about bike park opening hours, no more queuing for the chairlift in July and August! All the wildest areas are now open to you! It's a downhill bike which

pedals like an XC bike when going uphill, greatly opening up the range of possibilities which have been traditionally the territory of big downhill bikes.

Close your eyes and imagine yourself holding the handlebars, imagine the thrill of taking on the slope, of gaining

speed at every corner exit, jumping the biggest gap of the spot and imagine the pleasure you will feel when riding back uphill on singletracks!

It's a new era courtesy of the Samedi 27.5 LT, an era of absolute pleasure!!!



SAMEDI 27 LT 5



ENGAGED!

Reinforced aluminium 6061 T4 T6 frame. Variable thickness hydroformed tubes. Forged aluminium rocker link. Long travel, virtual pivot point, kinematic, very neutral and efficient. Adjustable travel 170 to 195mm.

Geometry designed to hit the roughest terrains while remaining extremely accessible and versatile to go down and climb back up any trails with a smile!

PERFORMING!

Rock Shox Kage RC shock, 240x76mm, switchable shock mounts to adapt travel to your liking, 175 or 195mm.

Rock Shox Yari RC fork, Motion Control, Solo Air, 27.5, 15mm Boost - Maxle Ultimate. 180 mm travel. Ultra powerful and progressive Magura MT5 hydraulic disk brakes, 4 pistons, 200mm front and rear rotors.

Continental Baron 27.5x2.4 tires, Black Chili compound offering fantastic grip.

ULTRA POWERFUL AND HIGHLY ENDURING

Bosch Performance CX, the most powerful and highest torque (75Nm) in the Bosch range. The market reference in terms of support. eMTB mode for enhanced performance in MTB usage. Equipped with 500Wh battery for maximum autonomy.

RELIABLE AND EFFICIENT

Sram GX 10 Speed 14x11/42 transmission with wide range to climb the steepest hills with ease. The Moustache chain guide avoids chain drop and "chain suck".



BOSCH PERFORMANCE CX
eMTB Mode
PURION DISPLAY



DRIVETRAIN SRAM GX 10S
14 X 11/42



BATTERY 500 WH
Autonomy:
see pages 12 to 14



SIZE
S43 (1,55 to 1,80 m)
L48 (1,80 to 1,95 m)



Long travel Rock Shox Yari RC fork, 180mm
Rock Shox Kage RC rear shock, 170/195mm
Magura MT5 200/200 brakes, 4 pistons

SAMEDI 27 LT 7



ENGAGED!

Reinforced aluminium 6061 T4 T6 frame. Variable thickness hydroformed tubes. Forged aluminium rocker link. Long travel, virtual pivot point, kinematic, very neutral and efficient - Adjustable travel 170 to 195mm.

Geometry designed to hit the roughest terrains while remaining extremely accessible and versatile to go down and climb back up any trails with a smile!

PERFORMING!

Market's favorite Rock Shox Vivid Air shock, 240x76mm, switchable shock mounts to adapt travel to your liking, 175 or 195mm.

Rock Shox Lyric RC fork, Motion Control, Solo Air, 27.5, 15mm Boost - Maxle Ultimate. 180 mm travel. Ultra powerful and progressive Magura MT5 hydraulic disk brakes, 4 pistons, 200mm front and rear rotors.

Continental Baron 27.5x2.4 tires, Black Chili compound offering fantastic grip.

ULTRA POWERFUL AND HIGHLY ENDURING

Bosch Performance CX, the most powerful and highest torque (75Nm) in the Bosch range. The market reference in terms of support. eMTB mode for enhanced performance in MTB usage. Equipped with 500Wh battery for maximum autonomy.

RELIABLE AND EFFICIENT

Sram XO1 11 Speed 14x10/42 transmission with wide range to climb the steepest hills with ease. The Moustache chain guide avoids chain drop and "chain suck".



BOSCH PERFORMANCE CX
eMTB Mode
PURION DISPLAY



DRIVETRAIN X01 11S
14 X 10/42



BATTERY 500 WH
Autonomy:
see pages 12 to 14



SIZE
S43 (1,55 to 1,80 m)
L48 (1,80 to 1,95 m)



Long travel Rock Shox Lyric RC, 180mm
Rock Shox Vivid Air rear shock, 170/195mm
Magura MT5 200/200 brakes, 4 pistons

SAMEDI 27 X2



AND WHAT IF WE DO AN E-TANDEM ???

Wow, that's not so stupid! It's a great idea, to increase and combine effort, or when the two riders do not have

the same level of fitness, with children, with a trailer, to go further, to bomb uphill (because everyone knows that

a tandem... it bombs along especially on the flat). **And presto, that's how a new challenge begins!**



1ST CHALLENGE: THE MOTOR...

Put it at the front, easy... but it's impossible to synchronize the cranks due to the motor freewheel... so, forget that if you want to maintain a decent ride.

Therefore we decided to put it at the rear... but we had to innovate! So we created a unique interface and special cranks to link the front and rear cranksets despite the motor being at the back.

2ND CHALLENGE: THE STIFFNESS!

Fortunately we already have our triple cavity tubes that have made our task easier!

3RD CHALLENGE: THE RANGE.

And for this we can thank Bosch who have developed a "Y" "DualBattery" wire to safely connect 2 batteries in order to get

an incredible capacity of 1000 Wh! The system intelligently manages power between the two batteries during charging and discharging, which increases their lifetime.



We almost forgot to mention high quality CNC hubs using Boost standard for stiffness, combine our exclusive rims and Maxxis 27.5x2.8 Rekon tires

for grip and comfort, the adjustable stem and the Suntour NCX seat post for comfort at the back!

We have also created a trekking alternative using reinforced SuperMotoX 27.5 x 2.35 tires which combine low rolling resistance and high loading potential. Mudguards and rear rack are optional.

We have also created a trekking alternative using reinforced SuperMotoX 27.5 x 2.35 tires which combine low rolling resistance and high loading potential. Mudguards and rear rack are optional.

DOUBLE THE SENSATION!

For family rides, rides with friends, rides with the kids, to go further, higher, and more often, to have a blast, have fun, travel... Dual battery : 2x500 Wh = 1000 Wh to give an endless ride... well almost ;-)

STRONG

Reinforced 6061 T4 T6 aluminium frame construction. Variable thickness hydroformed and extruded tubes.

PERFORMING

Central rear motor, synchronized crankarms for optimal efficiency. Rock Shox Yari RC fork, Motion Control, Solo Air, 27.5, 15mm Boost - Maxle Ultimate. 140 mm travel. Ultra powerful and progressive Magura MT5 hydraulic disk brakes, 4 pistons, 200mm front and rear rotors. 27.5+ wheels for maximum efficiency and grip whatever the terrain. Sealed annular bearings hubs for low friction and maximised autonomy. Asymmetrical welded aluminium rims, Moustache specific 35mm wide, tubeless compatible. Strong 27.5x2.8" Maxxis tires providing grip and dynamism for incredible fun.

COMFORTABLE

Suntour NCX suspended seat post offering unrivaled comfort. Moustache ergonomic saddle with anti-slip material to maintain best position when climbing the steepest climbs!

ULTRA POWERFUL AND HIGHLY ENDURING

Bosch Performance CX, the most powerful and highest torque (75Nm) in the Bosch range. The market reference in terms of support. eMTB mode for enhanced performance in MTB usage. Equipped with Dual 500Wh batteries for incredible autonomy.

RELIABLE AND EFFICIENT

High-end Shimano XT 11 Speed 14x11/42 transmission with wide range to climb the steepest hills with ease.

SAMEDI 27 X2 VTT / TRK



BOSCH PERFORMANCE CX
eMTB Mode
INTUVIA DISPLAY



DRIVETRAIN XT 11S
14 X 11/42



BATTERY 1000 WH (2 X 500 WH)
Autonomy:
see pages 12 to 14



SIZE
Front 51 (1,72 to 1,95m approximately)
Rear 42 (1,50 to 1,85m approximately)



Adjustable Stem

SPEED THE ULTIMATE RIDE!

The Speed range is the love-child of a lightweight, free-wheeling power-assisted bike and a speedy moped! The powerful Bosch Performance Speed motor will propel you efficiently up to 45 km/h and add spice to every trip you make!

L1e type moped approved.



FRIDAY 27 SPEED



PERFORMING!

6061 T4 T6 aluminium frame. Variable thickness hydroformed and extruded tubes. Polished welds. Optimised weight distribution. Lightweight and stiff. Balanced geometry. Reinforced carbon fork, ultra precise and light. 15mm Q-lock front wheel axle.

POWERFUL AND ENDURING

Bosch Performance Speed 350W system, dynamic, ultra powerful and with a high torque (63Nm). Provides continuous support up to 45 km/h. Equipped with the 500Wh battery for maximum autonomy.

SAFE

L1e certified, all components are reinforced, tested and approved for 45 km/h use. Magura MT4 180/180 hydraulic disk brakes. 45 km/h approved. Automatic fold up kickstand.

COMFORTABLE

Moustache ergonomic handlebar. Secure and balanced. Balloon tires 27.5x2.35 to filter the asphalt irregularities. Suspended seat post. Legendary Brooks saddle!

PRACTICAL!

Rear rack equipped with integrated QL3 fitting to attach Moustache Ortlieb panniers in one click.

RELIABLE AND EFFICIENT

Shimano XT 11 Speed 18x11/40 transmission, wide range, optimized autonomy. Moustache tubular aluminum mudguards, ultra-stable. Anti-puncture reinforcements.



BOSCH PERFORMANCE SPEED
INTUVIA DISPLAY



TRANSMISSION XT 11S
18 X 11/42



BATTERY 500 WH
Autonomy:
see pages 12 to 14



SIZE
S44 (1,50 to 1,65 m)
M48 (1,63 to 1,75 m)
L52 (1,73 to 1,85 m)
XL56 (1,83 to 1,95 m)



Carbon fork
SuperMoto X tires

PERFORMING!

6061 T4 T6 aluminium frame. Variable thickness hydroformed and extruded tubes. Polished welds. Aesthetics and design give birth to a perfectly balanced and dynamic geometry.

POWERFUL AND ENDURING

Bosch Performance Speed 350W system, dynamic, ultra powerful and with a high torque (63Nm). Provides continuous support up to 45 km/h. Equipped with the 500Wh battery for maximum autonomy.

SAFE

L1e certified, all components are reinforced, tested and approved for 45 km/h use. Magura MT4 180/180 hydraulic disk brakes. 45 km/h approved. Automatic fold up kickstand.

COMFORTABLE

The specific frame construction helps rear wheel vibrations to disperse throughout the top tube. Moustache ergonomic handlebar. Secured and balanced. Suntour MT45 suspended fork, 45 km/h specific. Suntour NCX suspended seat post and Selle Royal Viper Gel saddle offer unrivaled comfort.

PRACTICAL!

Rear rack equipped with integrated QL3 fitting to attach Moustache Ortlieb panniers in one click.

RELIABLE AND EFFICIENT

Shimano XT 11 Speed 18x11/40 transmission, wide range, optimized autonomy. Moustache tubular aluminum mudguards, ultra-stable. Anti-puncture reinforcements.

SAMEDI 28 SPEED



BOSCH PERFORMANCE SPEED
INTUVIA DISPLAY



DRIVETRAIN XT 11S
18 X 11/42



BATTERY 500 WH
Autonomy:
see pages 12 to 14



SIZE
S41 (1,55 to 1,70 m)
M47 (1,68 to 1,83 m)
L53 (1,81 to 1,95 m)



Suspended seatpost
Suntour NCX
Suntour MT45 fork

DIMANCHE 28 SPEED



PERFORMING!

6061 T4 T6 aluminium frame. Variable thickness hydroformed and extruded tubes. Polished welds. Optimised weight distribution. Lightweight and stiff. Balanced geometry. Reinforced carbon fork, ultra precise and light. 15mm Q-lock front wheel axle.

POWERFUL AND ENDURING

Bosch Performance Speed 350W system, dynamic, ultra powerful and with a high torque (63Nm). Provides continuous support up to 45 km/h. Equipped with the 500Wh battery for maximum autonomy.

SAFE

L1e certified, all components are reinforced, tested and approved for 45 km/h use. Magura MT4 180/180 hydraulic disk brakes. 45 km/h approved. Automatic fold up kickstand.

DYNAMIC

Semi-profiled rims. Fast-rolling and comfortable Schwalbe Durano E 700x37 tires.

RELIABLE AND EFFICIENT

Shimano 105 10 Speed 18x11/32 transmission. Anti-puncture reinforcements.



**BOSCH
PERFORMANCE
SPEED**
INTUVIA DISPLAY



**DRIVETRAIN
105 10S**
18 X 11/32



BATTERY 500 WH
Autonomy:
see pages 12 to 14



SIZE
S44 (1,50 to 1,65 m)
M48 (1,63 to 1,75 m)
L52 (1,73 to 1,85 m)
XL56 (1,83 to 1,95 m)



Carbon fork
Schwalbe Durano E
700 x 37

PERFORMING!

6061 T4 T6 aluminium frame. Variable thickness hydroformed and extruded tubes. Hollow tech alu/carbon rocker link. 140mm travel. Optimised weight distribution. Balanced Trail geometry for easy handling. Moustache air shock 200x51, 2 position platform, dynamic control of rebound, Grip Control Evo for incredible traction. Adjustable air pressure and rebound. Fox Float 34 Evolution CTD fork. 130mm travel. 45 km/h specific.

POWERFUL AND ENDURING

Bosch Performance Speed 350W system, dynamic, ultra powerful and with a high torque (63Nm). Provides continuous support up to 45 km/h. Equipped with the 500Wh battery for maximum autonomy.

SAFE

L1e certified, all components are reinforced, tested and approved for 45 km/h use. Magura MT4 180/180 hydraulic disk brakes. 45 km/h approved. Automatic fold up kickstand.

INNOVATIVE

Introduced in 2014, our differential wheels concept enhanced performance by combining 29" and 27.5" wheels! The 29" front wheel provides grip and comfort while the 27.5" rear wheel means dynamic behaviour and great handling capacities.

RELIABLE AND EFFICIENT

Sram 10 Speed 17x11/42 transmission, wide range to climb the steepest hills with ease! The Moustache chain guide avoids chain drop and "chain suck".

SAMEDI 27/9 SPEED



**BOSCH
PERFORMANCE
SPEED**
INTUVIA DISPLAY



**DRIVETRAIN
GX 10S**
17 X 11/42



BATTERY 500 WH
Autonomy:
see pages 12 to 14



SIZE
S41 (1,55 to 1,70 m)
M47 (1,68 to 1,83 m)
L53 (1,81 to 1,95 m)



Differentiated
wheels diameter
FOX 34
Performance fork

MERCREDI 12 BEGINNER KIDS



Frame aeronautical hydroformed variable thickness alloy, single tube / **Fork** Rigid fork, aeronautical alloy, single-sided / **Rims** alloy / **Tires** 12" mixed / **Saddle** Velo special kids' saddle / **Seatpost** integrated 25.4mm diameter / **Gaurantee** 5 years frame and fork, 2 years accessories / **Size** : saddle height adjustable from 34 to 41cm from the ground, suitable from approximately 20 months to 4/5 years / **Available in seven colours** / **Weight** : 3,4 kg

The Mercredi 12 is a bit of a special project: it was born by accident...but with the Moustache! We designed it for our own satisfaction, but also for our children. It's the only Moustache bike without electric pedal assistance, but it might be the most important one in our collection: it's a bike to begin riding that will give young riders the desire to continue. It's a bike without compromises,

that uses the same technologies as high-end adult models. The Mercredi 12 is designed to teach kids how to maintain balance on a bike. It's reassuring for children, because they can control their balance and speed with their feet. This will allow them to progress rapidly, and within a few short months you'll see your child pushing off and lifting up his or her feet

more and more often and for longer periods of time. And when he or she is finally old enough for a bike with pedals, you won't need training wheels!
The walkbike... It's magic!



ACCESSORIES

Here is the list of specific accessories to equip your Moustache bikes!

1 / Moustache waterproof bags (by Ortlieb) for use with carrier QL3.
2 / Kickstand adaptor for Samedi FS.
3 / Pletscher kickstand. **4** / Kickstand bracket for MTB OFF1 et OFF3.
5 / Front basket support for the Lundi 26. **6** / Front basket support for the Samedi 28 or the Friday 26. **7** / JUST Moustache 27.5+ aluminium wheels.
8 / JUST Moustache 27.5+ carbon wheels. **9** / Moustache side bottle cage. **10** / Pair of rack extensions for tall bags. **11** / AXA plug-in chain for frame lock. **12** / Rear carrier with Ortlieb QL3 mounts.



LUNDI 26

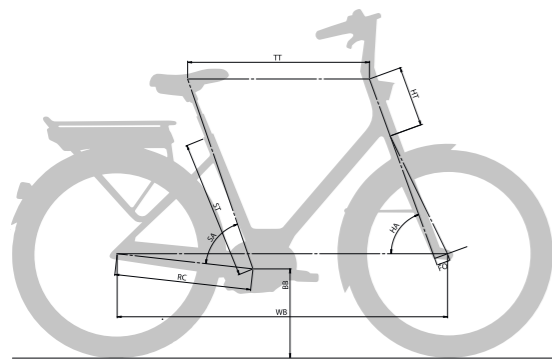

FRIDAY 27

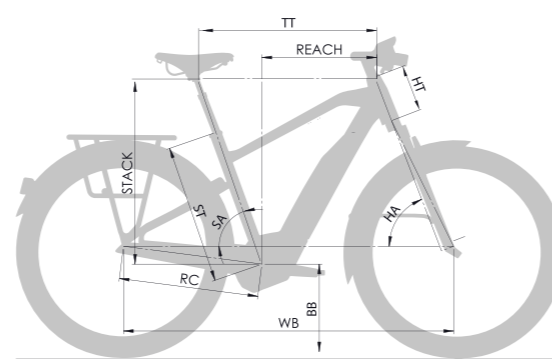

SAMEDI 28.1

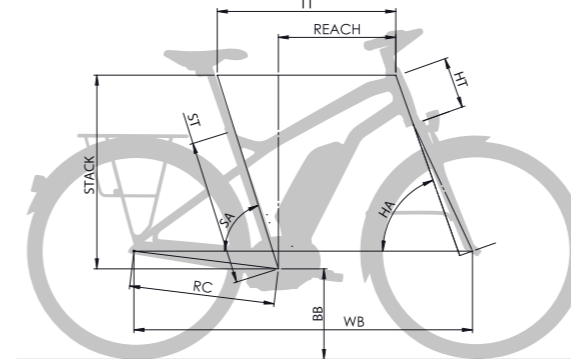

SAMEDI 28.1 OPEN

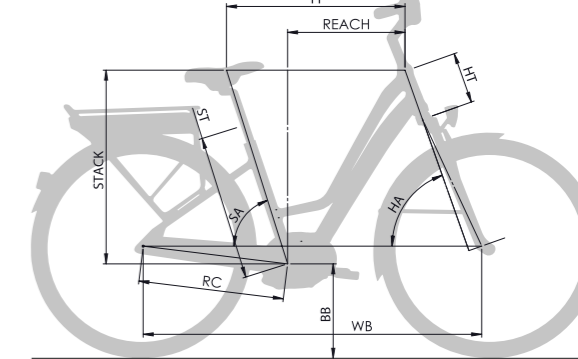

User (estimated fitting size)	1,57 - 1,90 m
Size (mm) - ST	460 (M)
Top tube (horizontal measure in mm) - TT	600
Chainstay (mm) - RC	451
Head Tube (mm) - HT	200
Wheel base (mm) - WB	1090
Fork length - FL	430
Bottom bracket (mm) - BB	285
Seat tube angle (°) - SA	71
Head angle (°) - HA	70
Seatpost mini with seatpost classical	59
Seatpost mini with seatpost suspended	62
Seatpost maxi	78

User (estimated fitting size)	1,50 - 1,65 m	1,68 - 1,83 m	1,81 - 1,95 m
Size (mm) - ST	410 (S)	470 (M)	530 (L)
Top tube (horizontal measure in mm) - TT	560	585	610
Chainstay (mm) - RC	470	470	470
Head Tube (mm) - HT	140	140	160
Wheel base (mm) - WB	1098	1113	1133
Bottom bracket (mm) - BB	297	297	297
Seat tube angle (°) - SA	71,3	71,3	71,3
Head angle (°) - HA	67,5	68	68,5
Reach (mm)	351	375	393
Stack (mm)	617	620	641

User (estimated fitting size)	1,55 - 1,70 m	1,68 - 1,83 m	1,81 - 1,95 m
Size (mm) - ST	410 (S)	470 (M)	530 (L)
Top tube (horizontal measure in mm) - TT	560	580	600
Chainstay (mm) - RC	452	452	452
Head Tube (mm) - HT	130	150	170
Wheel base (mm) - WB	1066	1081	1102
Bottom bracket (mm) - BB	298	298	298
Seat tube angle (°) - SA	71,5	71,5	71,5
Head angle (°) - HA	69	69,5	69,5
Reach (mm)	360	373	387
Stack (mm)	606	627	646

User (estimated fitting size)	1,55 - 1,70 m	1,68 - 1,83 m
Size (mm) - ST	410 (S)	480 (L)
Top tube (horizontal measure in mm) - TT	560	590
Chainstay (mm) - RC	481	481
Head Tube (mm) - HT	150	170
Wheel base (mm) - WB	1097	1122
Bottom bracket (mm) - BB	295	295
Seat tube angle (°) - SA	71,5	71,5
Head angle (°) - HA	69	69,5
Reach (mm)	355	378
Stack (mm)	625	646

SAMEDI 28.3 / 28.5

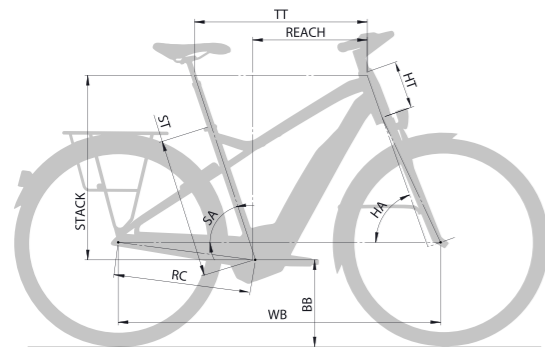

User (estimated fitting size)	1,55 - 1,70 m	1,68 - 1,83 m	1,81 - 1,95 m
Size (mm) - ST	410 (S)	470 (M)	530 (L)
Top tube (horizontal measure in mm) - TT	560	580	600
Chainstay (mm) - RC	457	457	457
Head Tube (mm) - HT	130	150	170
Wheel base (mm) - WB	1073	1087	1109
Bottom bracket (mm) - BB	305	305	305
Stack (mm)	604	625	644
Seat tube angle (°) - SA	71,5	71,5	71,5
Head angle (°) - HA	69	69,5	69,5
Reach (mm)	360	373	388

SAMEDI 28.3 / 28.5 OPEN

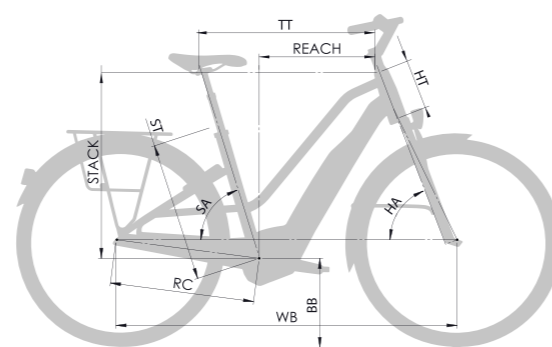

User (estimated fitting size)	1,49 - 1,61 m	1,59 - 1,76 m	1,74 - 1,90 m
Size (mm) - ST	390 (S)	450 (M)	510 (L)
Top tube (horizontal measure in mm) - TT	575	600	625
Chainstay (mm) - RC	490	490	490
Head Tube (mm) - HT	150	160	170
Wheel base (mm) - WB	1111	1128	1150
Bottom bracket (mm) - BB	298	298	298
Seat tube angle (°) - SA	71	70,5	70,5
Head angle (°) - HA	69	69	69,5
Reach (mm)	355	370	392
Stack (mm)	630	640	651

SAMEDI 27 XROAD 1

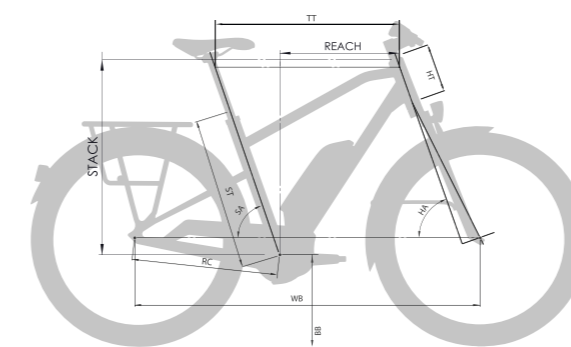

User (estimated fitting size)	1,55 - 1,70 m	1,68 - 1,83 m	1,81 - 1,95 m
Size (mm) - ST	410 (S)	470 (M)	530 (L)
Top tube (horizontal measure in mm) - TT	560	585	610
Chainstay (mm) - RC	470	470	470
Head Tube (mm) - HT	140	150	170
Wheel base (mm) - WB	1099	1119	1139
Bottom bracket (mm) - BB	298	298	298
Seat tube angle (°) - SA	71	71	71
Head angle (°) - HA	67,5	68	68,5
Reach (mm)	351	372	390
Stack (mm)	617	629	651

SAMEDI 27 OPEN XROAD 1

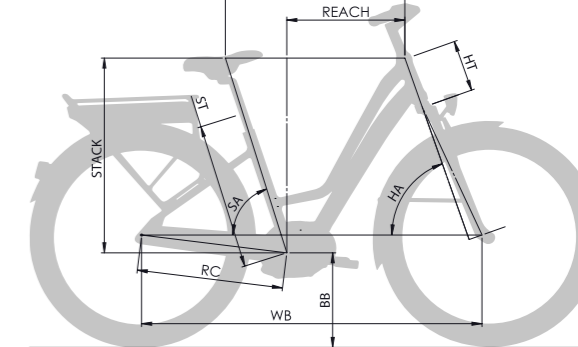

User (estimated fitting size)	1,55 - 1,70 m	1,68 - 1,83 m
Size (mm) - ST	410 (S)	480 (L)
Top tube (horizontal measure in mm) - TT	560	590
Chainstay (mm) - RC	481	481
Head Tube (mm) - HT	150	170
Wheel base (mm) - WB	1100	1125
Bottom bracket (mm) - BB	295	295
Seat tube angle (°) - SA	71,5	71,5
Head angle (°) - HA	69	69,5
Reach (mm)	351	375
Stack (mm)	627	648

SAMEDI 27 XROAD 3 / 5 / 7

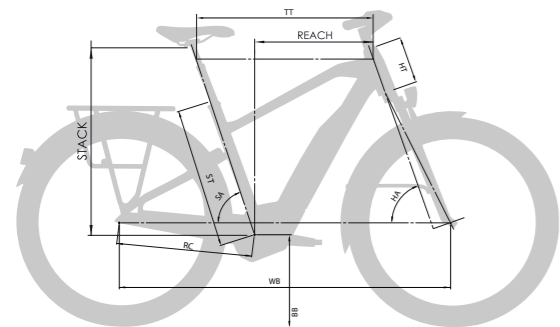

User (estimated fitting size)	1,55 - 1,70 m	1,68 - 1,83 m	1,81 - 1,95 m
Size (mm) - ST	410 (S)	470 (M)	530 (L)
Top tube (horizontal measure in mm) - TT	560	585	610
Chainstay (mm) - RC	470	470	470
Head Tube (mm) - HT	140	140	160
Wheel base (mm) - WB	1098	1116	1137
Bottom bracket (mm) - BB	298	298	298
Seat tube angle (°) - SA	71	71	71
Head angle (°) - HA	67,5	68	68,5
Reach (mm)	350	374	393
Stack (mm)	617	620	641

SAMEDI 27 OPEN XROAD 3 / 5 / 7

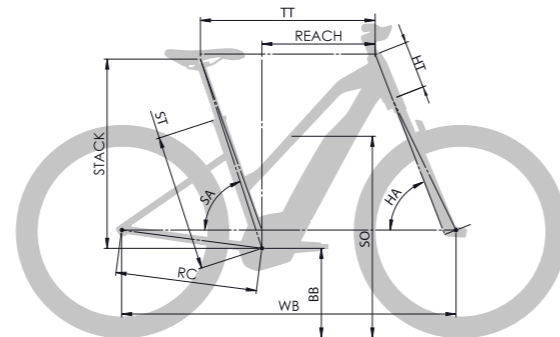

User (estimated fitting size)	1,55 - 1,70 m	1,68 - 1,83 m	1,81 - 1,95 m
Size (mm) - ST	390 (S)	450 (M)	510 (L)
Top tube (horizontal measure in mm) - TT	550	575	600
Chainstay (mm) - RC	470	470	470
Head Tube (mm) - HT	140	150	160
Wheel base (mm) - WB	1088	1106	1124
Bottom bracket (mm) - BB	297	297	297
Seat tube angle (°) - SA	71,5	71	71
Head angle (°) - HA	67,5	68	68,5
Reach (mm)	346	364	385
Stack (mm)	616	627	640

DIMANCHE 28 FITNESS 1 / 3

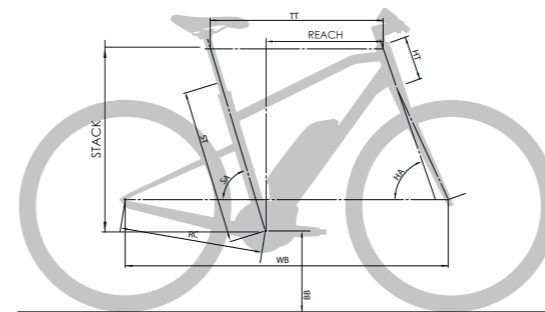

User (estimated fitting size)	1,55 - 1,70 m	1,68 - 1,83 m	1,81 - 1,95 m
Size (mm) - ST	410 (S)	470 (M)	530 (L)
Top tube (horizontal measure in mm) - TT	560	585	610
Chainstay (mm) - RC	470	470	470
Head Tube (mm) - HT	140	150	170
Wheel base (mm) - WB	1090	1110	1131
Bottom bracket (mm) - BB	292	292	292
Seat tube angle (°) - SA	72,5	72,5	72,5
Head angle (°) - HA	69	69,5	70
Reach (mm)	365	386	405
Stack (mm)	611	623	644

SAMEDI 27 X2 VTT / TRK

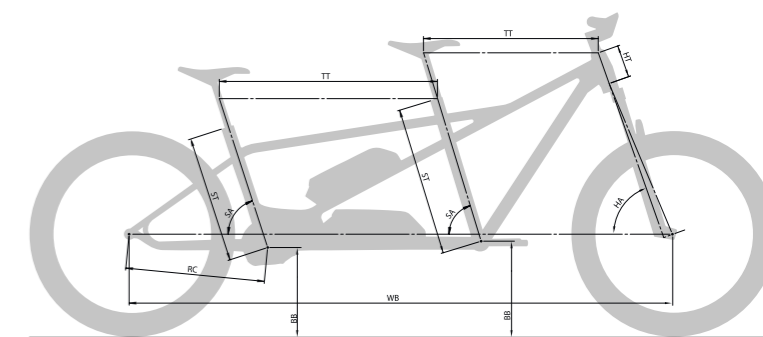

User (estimated fitting size)	1,55 - 1,80 m	1,80 - 1,95 m
Size (mm) - ST	430 (S)	480 (L)
Top tube (horizontal measure in mm) - TT	591	629
Chainstay (mm) - RC	460	460
Head Tube (mm) - HT	110	110
Wheel base (mm) - WB	1212	1251
Rake (mm) - FO	51	51
Bottom bracket (mm) - BB	357	357
Seat tube angle (°) - SA	74,3	74,3
Head angle (°) - HA	64,8	64,8
Wheel size Rear / Front (")	27,5 / 27,5	27,5 / 27,5
Reach - (mm)	421	459
Stack - (mm)	600	600

SAMEDI 27 OFF

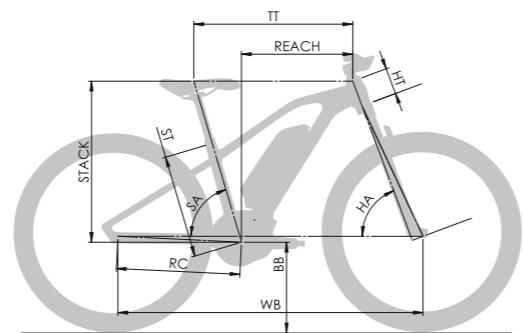

User (estimated fitting size)	1,33 - 1,50 m
Size (mm) - ST	350 (XS)
Top tube (horizontal measure in mm) - TT	540
Chainstay (mm) - RC	438
Head Tube (mm) - HT	90
Wheel base (mm) - WB	1150
Bottom bracket (mm) - BB	300
Seat tube angle (°) - SA	73,5
Head angle (°) - HA	70
Reach (mm)	378
Stack (mm)	547

SAMEDI 27 OFF 2

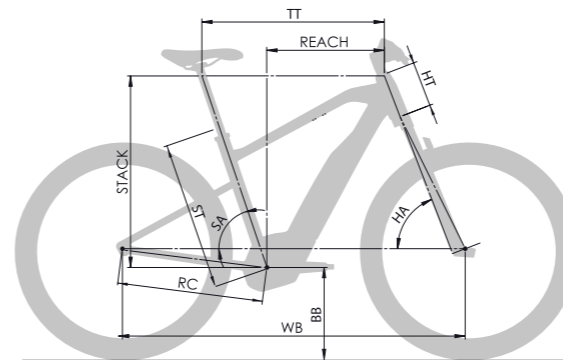

User (estimated fitting size)	1,55 - 1,70 m	1,68 - 1,83 m	1,81 - 1,95 m
Size (mm) - ST	410 (S)	470 (M)	530 (L)
Top tube (horizontal measure in mm) - TT	560	585	610
Chainstay (mm) - RC	470	470	470
Head Tube (mm) - HT	140	140	160
Wheel base (mm) - WB	1105	1124	1144
Bottom bracket (mm) - BB	305	305	305
Seat tube angle (°) - SA	70	70	70
Head angle (°) - HA	66,5	67	67,5
Reach (mm)	340	364	382
Stack (mm)	623	626	648

SAMEDI 27 OFF 2 OPEN

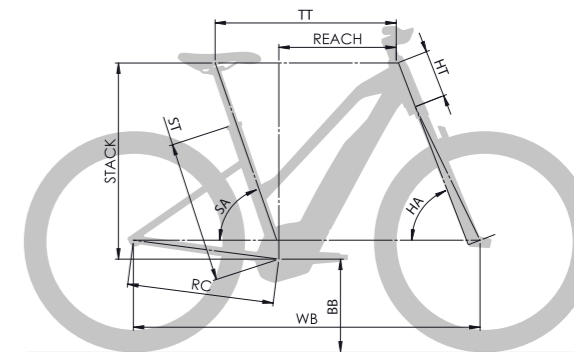

User (estimated fitting size)	1,49 - 1,61 m	1,59 - 1,76 m	1,74 - 1,90 m
Size (mm) - ST	390 (S)	450 (M)	510 (L)
Top tube (horizontal measure in mm) - TT	550	575	600
Chainstay (mm) - RC	470	470	470
Head Tube (mm) - HT	140	150	160
Wheel base (mm) - WB	1095	1113	1131
Bottom bracket (mm) - BB	305	305	305
Seat tube angle (°) - SA	70,5	70	70
Head angle (°) - HA	66,5	67	67,5
Reach (mm)	335	353	374
Stack (mm)	621	633	646

SAMEDI 27 OFF 4 / 6 / 8

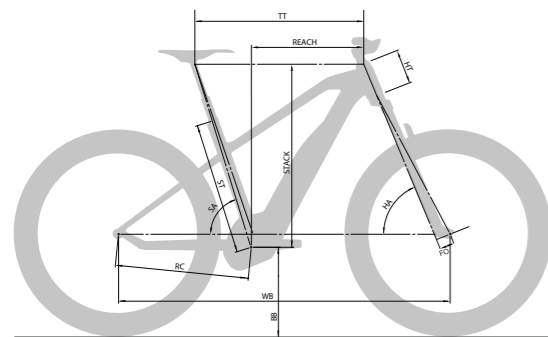

User (estimated fitting size)	1,55 - 1,70 m	1,68 - 1,83 m	1,81 - 1,95 m
Size (mm) - ST	400 (S)	460 (M)	520 (L)
Top tube (horizontal measure in mm) - TT	565	590	620
Chainstay (mm) - RC	459	459	459
Head Tube (mm) - HT	100	110	130
Wheel base (mm) - WB	1132	1158	1190
Bottom bracket (mm) - BB	322	322	322
Seat tube angle (°) - SA	73,3	73,3	73,3
Head angle (°) - HA	67,7	67,7	67,7
Reach (mm)	375	398	422
Stack (mm)	617	626	645

SAMEDI 27 TRAIL

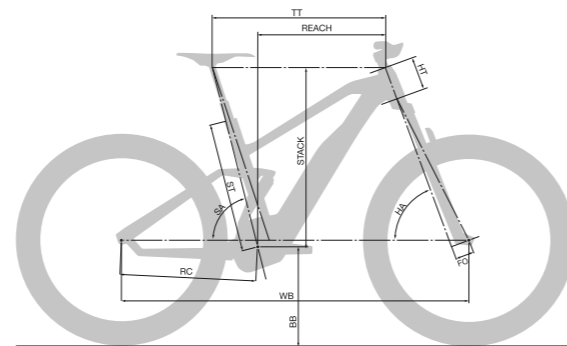

User (estimated fitting size)	1,53 - 1,70 m	1,68 - 1,85 m	1,83 - 2,00 m
Size (mm) - ST	400 (S)	440 (M)	500 (L)
Top tube (horizontal measure in mm) - TT	565	600	630
Chainstay (mm) - RC	465	465	465
Head Tube (mm) - HT	100	110	130
Wheel base (mm) - WB	1160	1196	1229
Rake (mm) - FO	51	51	51
Bottom bracket (mm) - BB	342	342	342
Seat tube angle (°) - SA	74,6	74,6	74,6
Head angle (°) - HA	67,6	67,6	67,6
Wheel size (")	27,5+	27,5+	27,5+
Reach - (mm)	404	436	461
Stack - (mm)	602	611	629

SAMEDI 27 RACE

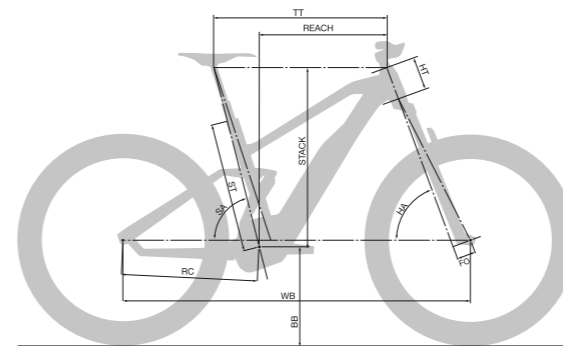

User (estimated fitting size)	1,53 - 1,70 m	1,68 - 1,85 m	1,83 - 2,00 m
Size (mm) - ST	400 (S)	440 (M)	500 (L)
Top tube (horizontal measure in mm) - TT	565	600	630
Chainstay (mm) - RC	465	465	465
Head Tube (mm) - HT	100	110	130
Wheel base (mm) - WB	1168	1204	1236
Rake (mm) - FO	51	51	51
Bottom bracket (mm) - BB	349	349	349
Seat tube angle (°) - SA	73,7	73,7	73,7
Head angle (°) - HA	66,5	66,5	66,5
Wheel size (")	27,5+	27,5+	27,5+
Reach - (mm)	404	436	461
Stack - (mm)	602	611	629

SAMEDI 27 LT

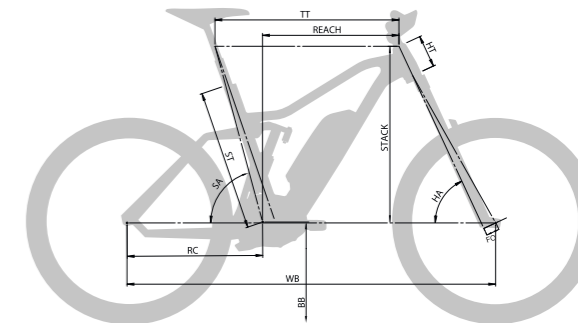

User (estimated fitting size)	1,55 - 1,80 m	1,80 - 1,95 m
Size (mm) - ST	430 (S)	480 (L)
Top tube (horizontal measure in mm) - TT	591	629
Chainstay (mm) - RC	460	460
Head Tube (mm) - HT	110	110
Wheel base (mm) - WB	1212	1251
Rake (mm) - FO	51	51
Bottom bracket (mm) - BB	357	357
Seat tube angle (°) - SA	74,3	74,3
Head angle (°) - HA	64,8	64,8
Wheel size Rear / Front (")	27,5 / 27,5	27,5 / 27,5
Reach - (mm)	421	459
Stack - (mm)	600	600

FRIDAY 27 SPEED

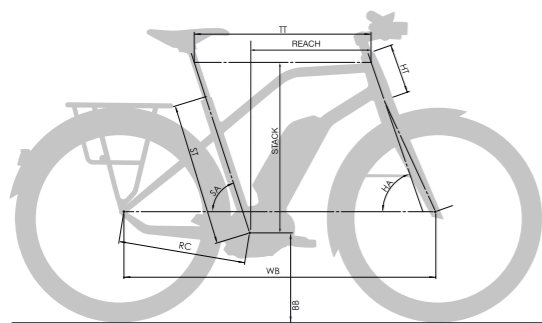

User (estimated fitting size)	1,50 - 1,65 m	1,63 - 1,75 m	1,73 - 1,85 m	1,83 - 1,95 m
Size (mm) - ST	440 (S)	480 (M)	520 (L)	560 (XL)
Top tube (horizontal measure in mm) - TT	560	580	600	620
Chainstay (mm) - RC	475	475	475	475
Head Tube (mm) - HT	140	165	190	210
Wheel base (mm) - WB	1076	1081	1096	1100
Bottom bracket (mm) - BB	296	296	296	296
Seat tube angle (°) - SA	72,6	71,6	71,6	70,6
Head angle (°) - HA	70,6	71,1	71,6	72,6
Reach (mm)	394	400	411	411
Stack (mm)	570	605	621	647

SAMEDI 28 SPEED

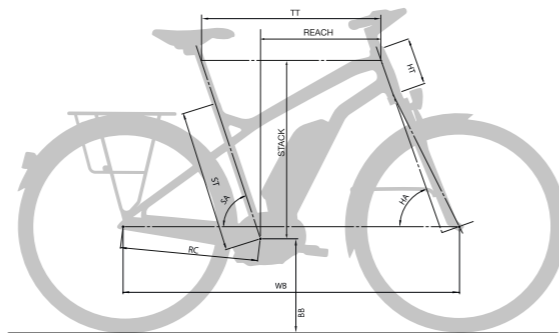

User (estimated fitting size)	1,55 - 1,70 m	1,68 - 1,83 m	1,81 - 1,95 m
Size (mm) - ST	410 (S)	470 (M)	530 (L)
Top tube (horizontal measure in mm) - TT	560	580	600
Chainstay (mm) - RC	452	452	452
Head Tube (mm) - HT	130	150	170
Wheel base (mm) - WB	1066	1081	1102
Bottom bracket (mm) - BB	298	298	298
Seat tube angle (°) - SA	71,5	71,5	71,5
Head angle (°) - HA	69	69,5	69,5
Reach (mm)	360	373	387
Stack (mm)	606	627	646

DIMANCHE 28 SPEED

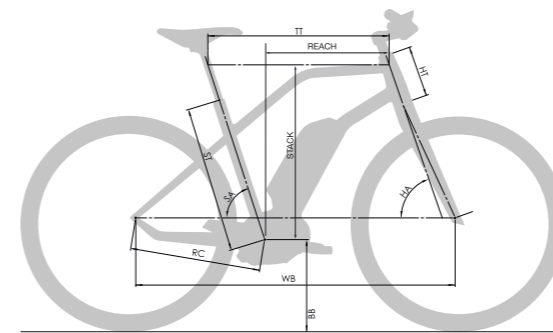

User (estimated fitting size)	1,50 - 1,65 m	1,63 - 1,75 m	1,73 - 1,85 m	1,83 - 1,95 m
Size (mm) - ST	440 (S)	480 (M)	520 (L)	560 (XL)
Top tube (horizontal measure in mm) - TT	560	580	600	620
Chainstay (mm) - RC	475	475	475	475
Head Tube (mm) - HT	140	165	190	215
Wheel base (mm) - WB	1076	1081	1096	1100
Bottom bracket (mm) - BB	291	291	291	291
Seat tube angle (°) - SA	72,6	71,6	71,6	70,6
Head angle (°) - HA	70,6	71,1	71,6	72,1
Reach (mm)	394	400	411	411
Stack (mm)	570	605	621	647

SAMEDI 27/9 SPEED

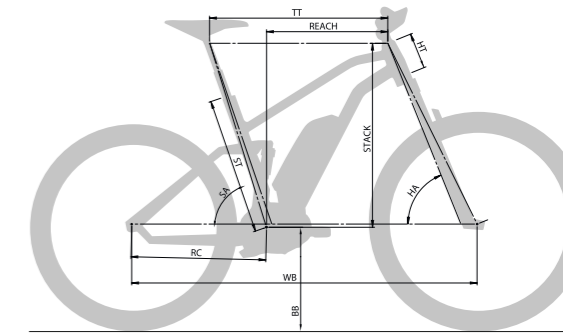

User (estimated fitting size)	1,55 - 1,70 m	1,68 - 1,83 m	1,81 - 1,95 m
Size (mm) - ST	410 (S)	470 (M)	530 (L)
Top tube (horizontal measure in mm) - TT	575	600	625
Chainstay (mm) - RC	456	456	456
Head Tube (mm) - HT	100	120	140
Wheel base (mm) - WB	1121	1148	1174
Bottom bracket (mm) - BB	333	333	333
Seat tube angle (°) - SA	73	73	73
Head angle (°) - HA	68,5	68,5	68,5
Reach (mm)	398	418	437
Stack (mm)	603	622	641

P.18 - **LUNDI 26**
PRACTICAL URBAN



P.26 - **FRIDAY 27**
SPORTY URBAN



P.34 - **SAMEDI 28**
VERSATILE TREKKING



P.44 - **SAMEDI 27 XROAD**
MULTI-PURPOSE ROAD / ALL TERRAIN



P.56 - **DIMANCHE 28**
LEISURE OR PERFORMANCE ROAD



P.62 - **SAMEDI 27**
RECREATIONAL MTB



P.108 - **SPEED**
THE ULTIMATE RIDE



{MOUSTACHE

BIKES

www.moustachebikes.com

e-powered by



SAS CYCLE ME // 9, RUE DU COLONEL DEMANGE // 88190 GOLBEY // FRANCE // CONTACT@MOUSTACHEBIKES.COM